

# SINGLE ACTING ALTITUDE VALVE

Purpose: Prevent overflow in elevated storage    Model Number: 30AWR

**Sizes:** 4" - 48"

**Type:** Nonthrottling

**Primarily Controlled By:**

Hydraulic pressure

**Located:** In line leading to storage

**Purpose:** To prevent elevated storage from overflowing

**Band:** Fixed within 9" - 4'

**Inlet Pressure:** Maximum: 300 psi

**Inlet Pressure:** Minimum: 5 psi

**Construction:** Body: 4" - 36" - Cast iron (semi-steel) with bronze trim  
40" - 48" - Ductile iron, with bronze/ stainless steel trim

**Plugged Tee:** Incorporated in piping for attachment of a separate sensing line - if provided

**Control Devices:**

**Strainer:** Model 5F-2

**Pilot:** Model 30AWR

See overall parts lists and specific parts information for complete details.

## Options

1. Cast steel or ductile iron body and stainless steel trim
2. External spring assists (to open or close) - For low head applications.
3. Auxiliary pilot added to the control circuit - For faster operation (standard on valve sizes 20 inches and larger.)
4. Teflon coated cylinders

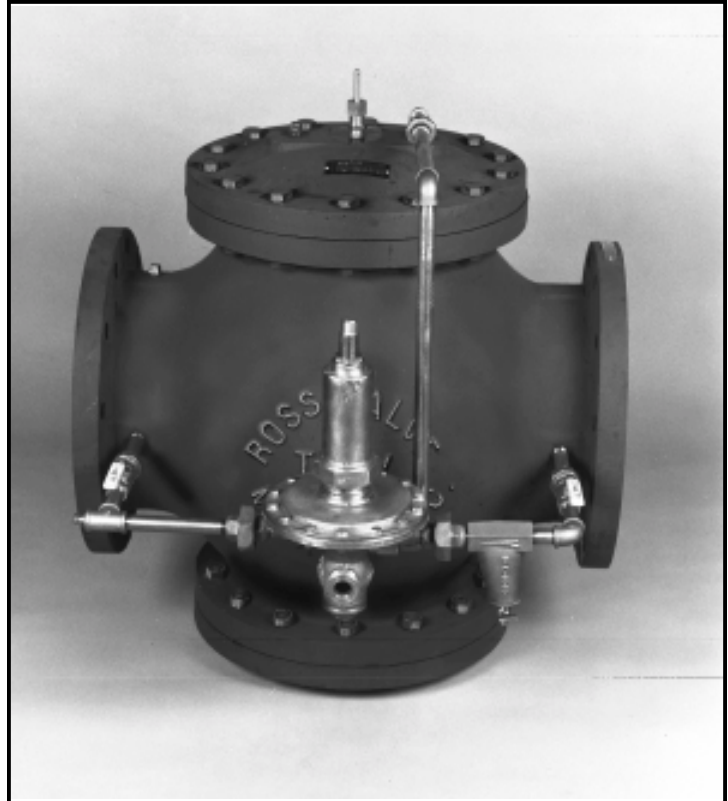

Ross engineers customize the basic **30AWR** to accommodate individual needs.

## Customized Features

Any one or a selection of features can be added to the basic single acting - non throttling altitude valve.

### Code

**D** - Delayed Opening Feature: Second Altitude Pilot Valve

**CI** - Check Feature (Internal)

**N** - Speed Control Valve

**SG** or **SF** - Solenoid Pilot Valve: 3 Way

(Can be modified to stay closed once actuated and require manual opening - latching action)

**ES** - Higher Efficiency Strainer

**LS** - Limit Switch

(Basic Applications on next page)

# SINGLE ACTING ALTITUDE VALVE

Basic Applications
Customized Features

## Basic Applications

1. Control level in a tank.
2. Prevent emptying a hydro pneumatic tank.
3. Conserve a reserve emergency supply in a tank.

The minimum water level is preset at the factory to be a constant distance below the maximum level no matter what maximum is set. The maximum is adjustable. *The norm for the difference between high and low is between 9" and 4'.*

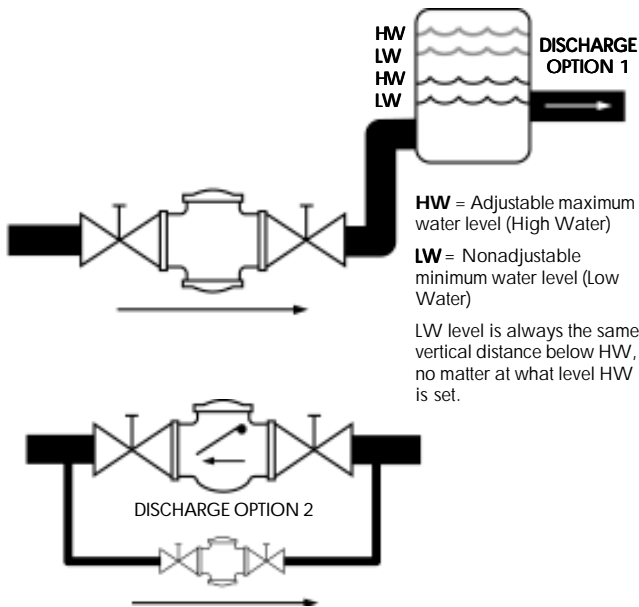

- If:** Level in the tank reaches the maximum setting  
**Ross Main Valve will:** Full close to prevent flow from supply into storage.
- If:** Enough water is discharged from storage to reduce the level (pressure) in the tank to the minimum setting  
**Ross Main Valve will:** Full open to let more water flow from supply to storage.

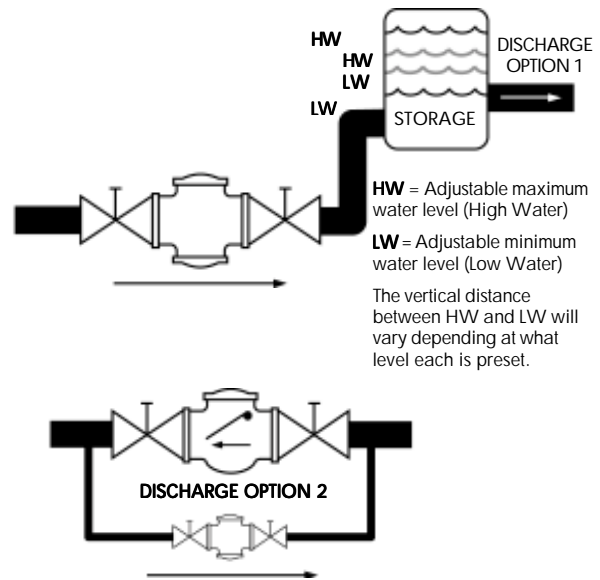

## D - Delayed Opening Feature: Second Altitude Pilot Valve

- Primarily Controlled By:** Hydraulic (pressure storage)  
**Located:** On external piping  
**Purpose:** To control the main valve opening independently from controlling its closing  
**BASIC APPLICATION:** Change the band by more than 4' between closing and opening points.
1. The high water level is adjustable.  
**If:** Level in the tank reaches its high setting  
**Ross Main Valve will:** Full close to prevent flow from supply into storage.
  2. The low level is adjustable. Therefore, the height of the band (the vertical distance between the maximum and minimum water level in the tank) can be controlled according to specific need.  
**If:** Enough water is discharged from storage to the user so the level (pressure) in storage falls to its low setting  
**Ross Main Valve will:** Full open to discharge more water from supply into storage.
- CAUTION:** In almost all instances, 4' is a minimum required difference between the 2 settings.  
**CONSULT A ROSS ENGINEER:** On what to do if the difference between the 2 settings needs to be less than 4'.

COMMON CONFIGURATIONS	
1	30AWR-D
2	30AWR-CI
3	30AWR-SG or 30AWR-SF

# SINGLE ACTING ALTITUDE VALVE

Model Number: 30AWR

## CI - Check Feature (Internal Modification)

**Primarily Controlled By:** Hydraulic pressure

**Located:** Inside the main valve

**Purpose:** To prevent reverse flow through the main valve

**BASIC APPLICATION:** In situations, for example if the supply line in a separate fill-empty system breaks, provides extra protection against dumping the tank, by extra protecting against backflow.

**NOTE:** The exact modification differs according to need. Some types can only be incorporated in the factory before the valve is shipped and, once done, can't be changed without substantial parts replacement.

**CONSULT A ROSS ENGINEER:**

1. Whether to use an internal check or speed control valve. The choice is determined by several factors specific to the valve being customized.
2. To recommend the appropriate internal modification, if that is the choice.

## N - Speed Control Valve

**Primarily Controlled By:** Hydraulic pressure

**Located:** On external piping

**Purpose:** In very specific circumstances, to control the valve closure rate on pressure reversal

**BASIC APPLICATION:** Minimize surge on closure by controlling the valve closure rate.

**NOTE:** Internal porting on the Ross pilot valves regulates speed control. In almost all instances an external speed control valve is not necessary.

**CONSULT A ROSS ENGINEER:** To determine if this feature is appropriate for a specific set of conditions.

## SG - Opens Valve When Energized:

## SF - Opens Valve When De-energized:

## Solenoid Pilot Valve - 3 Way

**Primarily Controlled By:** Electricity

**Located:** On external control circuit at the juncture leading to mainline storage, the hydraulic pilot and operating chamber  
Three openings and two ports control pressure in the operating chamber:

- 1 Opening - to the operating chamber
- 1 Opening - to the line (controlled by 1 port)
- 1 Opening - to waste (controlled by 1 port)

*A 3 way solenoid pilot is always open to the operating chamber.*

**Purpose:** To override the hydraulic pilot and lock the main valve in a CLOSED position

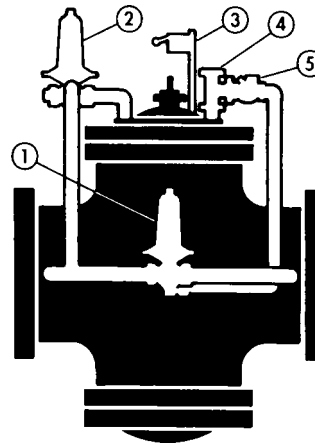

### FEATURES

- 1 Pilot Valve (Standard)
- 2 Pilot Valve (Delayed Opening)
- 3 LS - Limit Switch
- 4 Needle Valve (Speed Control)
- 5 CE - Check Valve

### BASIC APPLICATION:

1. Remove the valve's control over the line flow/pressure so the system operates as if no valve is involved.
2. Allow the main valve to function in a predetermined manner in case of a power outage.

**OPERATION:** Energizing and de-energizing the solenoid pilot controls the main valve.

### OPTION 1 - When the pilot is:

**De-Energized** - Port to the line opens/waste port closes which allows the main valve to operate as a single acting altitude valve.

**Energized** - Port to the line closes/waste port opens which locks the valve in a WIDE OPEN position.

### OPTION 2 - When the pilot is:

**De-Energized** - Port to the line closes/waste port opens which locks the valve in a WIDE OPEN position.

**Energized** - Port to the line opens/waste port closes which allows the main valve to operate as a single acting altitude valve.

## ES - Higher Efficiency Strainer

**Located:** On external piping.

**Purpose:** To provide extra protection against fouling or damaging the control system from foreign particles

**BASIC APPLICATION:** Protect external piping and controls when extremely fine particles and/or more than usual debris is expected.

**NOTE:** this strainer offers an increased capacity to hold debris and comes with a finer screen than the standard model.

## LS - Limit Switch

**Primarily Controlled By:** Valve position indicator

**Located:** Attached to a valve position indicator

**Purpose:**

1. To signal if the valve is opened or closed
2. To start or stop allied equipment

# SINGLE ACTING ALTITUDE VALVE

## Operation

### Control Unit

By regulating the flow in and out of the operating chamber, an external piping circuit accurately controls the piston open/closed position. It includes:

1. Hydraulic pilot valve - Controls flow into and out of the operating chamber by means of a
  - a. Diaphragm attached to a stem and balanced between a spring load on its top side and storage side water pressure underneath.
  - b. Second seat/spring attached to the lower end of the stem. (The spring resistance controlling the maximum pressure is preset and can be adjusted when pressure requirements change.)
2. External piping - Three basic piping segments - All connected to the hydraulic pilot valve and one each to the:
  - a. Inlet side of the main line valve.
  - b. Storage side of the main line valve.
  - c. Operating chamber.

### Operation

The valve is either fully open or fully closed. There is no in between. This straight forward operation provides the necessary control to maintain preset storage levels.

1. When storage pressure reaches its high water level, the
  - a. Downstream water backs up through the external pipe, into the pilot valve, pushing the diaphragm up.
  - b. Pilot valve seat between the upper and lower stem opens.
  - c. Water flows from the supply side of the main valve, through the external pipe, through the pilot valve, through the pipe leading into the operating chamber, where it has no way out.
  - d. Pressure builds up in the operating chamber, pushing the piston down.
  - e. Main line valve fully closes.
2. When storage pressure reaches its low water level (fixed within 9" to 4'), the
  - a. Spring loading overcomes the water pressure under the diaphragm.
  - b. Expanded top spring:
    1. closes the pilot seat that allows water to flow from the supply side of the main line valve through the external piping and into the operating chamber.
    2. opens the lower seat on the lower stem of the pilot valve to empty the operating chamber to waste.
  - c. Pressure above the piston drops when water flows out of the operating chamber.
  - d. Piston rises and the main valve fully opens.

### Caution

1. With a basic, single acting (one way flow) altitude valve, water must be withdrawn from the tank or basin through a separate line or through a swing check valve in piping around the altitude valve.
2. A SEPARATE SENSING LINE from the control circuit to the tank allows the most accurate control.
3. A SEPARATE SENSING LINE IS NECESSARY if the valve is located 25 ft. or more from the tank so that the head loss between the valve and the tank is significant or if the inlet pressure is high in relation to the tank head (more than 20 psi).
4. Provision should be made in the pit (sump pump or drain) to dispose of this small quantity of water discharged ONLY WHEN THE VALVE IS IN THE PROCESS OF OPENING. Discharge will range from 0.15 gal. for a 4 inch valve to 15.7 gal. for a 24 inch valve.
5. A LIFTING HOOK should be over the valve or the valve should be located under a manhole or hatch for valves larger than 12 inches.
6. Main line ISOLATION VALVES (plus a small bypass line if necessary) should be provided on the valve inlet and outlet for serving the altitude valve.
7. It is important to service the pilot periodically in order to insure dependable service.

### Consult a Ross Representative

To build a customized valve for any specific requirements.

### ROSS ADVANTAGE

1. Ross engineers provide in depth service based on
  - a. state of the art technology and
  - b. the company's experience which dates back to 1879.
2. Globe body design provides most desirable characteristics to monitor flow into storage.
3. Valve operates totally on hydraulic pressure. No external controls are needed.
4. Valve is completely pre-piped, tested and adjusted in the factory.
5. Rugged construction materials provide a longer valve life and insure that the valve WILL NOT experience sudden breakdowns due to component failures.
6. All parts are built and manufactured in the USA.

# SINGLE ACTING ALTITUDE VALVE

Model Number: 30AWR

## Additional Information

Item	Page
Alternative Seats .....	EN - 12
Differential Pressure Guide .....	EN - 6
Dimensions - Angle Body (Without Controls) .....	EN - 16
- Globe Body (Without Controls) .....	EN - 14
- Standard External Controls .....	EN - 21
- Strainers .....	EN - 26, 27
Head Loss Guide .....	EN - 3
Limit Switch .....	EN - 50
Needle Valve .....	EN - 47
Parts List - Angle Body (Without Controls) .....	EN - 31
- Globe Body (Without Controls) .....	EN - 30
- Standard External Controls .....	EN - 32
- Strainers .....	EN - 42
Solenoid Pilot Valves .....	EN - 49

## Approximate Shipping Weights (lbs.)

Valve Size	4"	6"	8"	10"	12"	14"	16"	18"	20"	24"	30"	36"	42"	48"
125 lb. Flanges	290	430	790	990	1530	2120	2750	3400	4170	5200	9800	11800	18300	23000
250 lb. Flanges	330	485	870	1070	1610	2275	2900	3600	4520	5500	10800	12800	19400	24500

## Volume of Liquid Exhausted When the Valve Opens

Valve Size	4"	6"	8"	10"	12"	14"	16"	18"	20"	24"	30"	36"	42"	48"
Cubic Inches	34	82	188	314	565	923	1355	2200	2200	3620	6730	9160	23013	34743
Gallons	0.15	0.35	0.81	1.36	2.44	4.00	5.87	9.50	9.50	15.70	29.00	39.60	99.62	150.4

**Caution:** Provision should be made in the valve chamber to dispose of the waste water.

# SINGLE ACTING ALTITUDE VALVE

Pilot Valves

Model Number: 30AWR

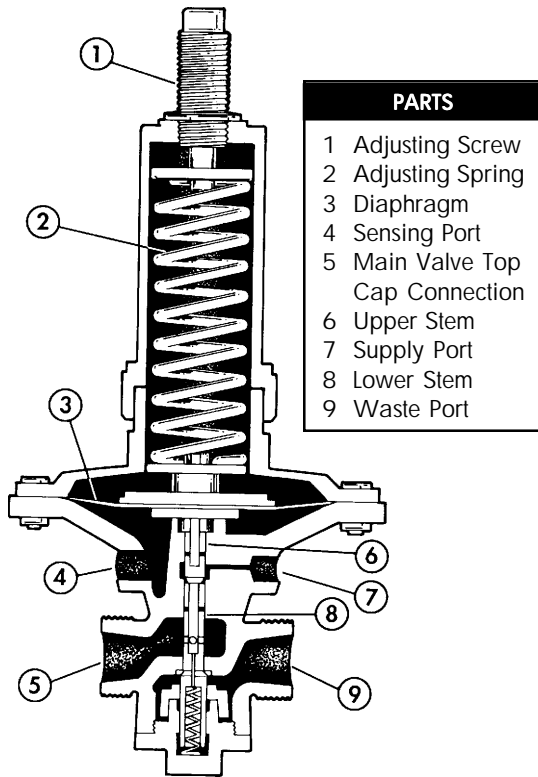

- | PARTS |                               |
|-------|-------------------------------|
| 1     | Adjusting Screw               |
| 2     | Adjusting Spring              |
| 3     | Diaphragm                     |
| 4     | Sensing Port                  |
| 5     | Main Valve Top Cap Connection |
| 6     | Upper Stem                    |
| 7     | Supply Port                   |
| 8     | Lower Stem                    |
| 9     | Waste Port                    |

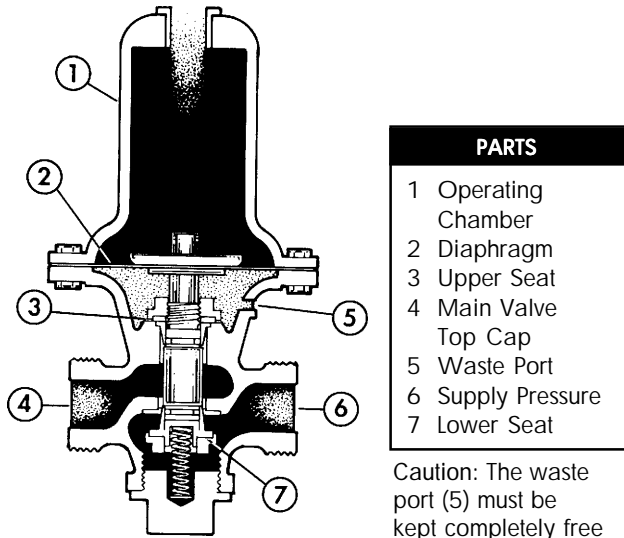

- | PARTS |                    |
|-------|--------------------|
| 1     | Operating Chamber  |
| 2     | Diaphragm          |
| 3     | Upper Seat         |
| 4     | Main Valve Top Cap |
| 5     | Waste Port         |
| 6     | Supply Pressure    |
| 7     | Lower Seat         |

Caution: The waste port (5) must be kept completely free for discharge.

## Pilot: External Sensing Port

**Primarily Controlled By:** Hydraulic pressure  
**Located:** On external piping which is connected to the inlet side, the outlet side and the operating chamber  
**Purpose:** To prevent high storage from exceeding a preset maximum level

## Operation

- When the pressure in storage reaches its high water level, the
  - Storage pressure backs up into the pilot valve, pushing the diaphragm up.
  - Pilot seat between upper and lower stems opens letting water flow from the supply side into the operating chamber.
  - Main valve closes.
- When the pressure in storage reaches its low water level, the
  - Top spring loading pushes the pilot diaphragm down.
  - Seat that controls the supply flow closes.
  - Another seat that leads to waste opens and water flows out of the operating chamber.
  - Main valve opens.

## Pilot: Auxiliary

**Subordinate to the primary pilot/Provides larger ports**  
**Primarily Controlled By:** Hydraulic pressure  
**Located:** On external piping which is connected to the inlet side, waste, operating chamber and primary pilot valve  
**Purpose:** To accommodate the larger volumes of water required to open and close the larger valves

## Operation

- When pressure sensed by the primary pilot exceeds its preset level, the
  - Water enters an auxiliary top port, closing the seat to waste and opening the seat from supply to the operating chamber.
  - Operating chamber fills more rapidly than it would without an auxiliary.
  - Main valve closes more rapidly.
- When pressure sensed by the primary pilot falls below its preset level, the
  - Top pressure decreases, causing the stem to rise and open the port to waste, close the port to supply.
  - Operating chamber empties more rapidly than it would without an auxiliary.
  - Main valve opens more rapidly.

## Standard Pilot Adjustment Ranges

These ranges should be used as a guide only. When specific operating conditions are known, the pilot is constructed to give at least a 30% adjustment above and below the anticipated set point. Standard pilot adjustment ranges: 4 to 12 ft.; 8 to 25 ft.; 18 to 60 ft.; 50 to 90 ft.; 75 to 140 ft.; 120 to 200 ft.

**Factory:** Telephone (518) 274-0961; Fax (518) 274-0210

# SINGLE ACTING ALTITUDE VALVE

## Specifications

Model Number: 30AWR

## Basic Valve: Single Acting Altitude (30AWR)

The altitude valve shall be single acting, closing to prevent overflow when high water level is reached and opening for refilling when the tank or reservoir water level lowers.

The altitude valve shall be ruggedly constructed with a size inch, 125 lb./250 lb. flanged, full ported globe body design.

The altitude valve shall be fully bronze mounted, external pilot operated, with free floating piston (operated without springs, diaphragm or levers), single seat with seat bore equal to size of valve.

Non-throttling action is required for operation either fully open or fully closed.

The minimum travel of the piston shall be equal to 25% of the diameter of the seat

For true alignment (to correct lateral thrust and stem binding) the piston shall be guided above and below the seat a distance equal to no less than 75% of the seat diameter to insure lateral thrust.

The piston shall carry a contoured cushion device that will cause a gradual change in flow area as the valve approaches the seat. The cushion device must move with the piston to minimize head loss when the valve is fully opened and so designed as to insure positive closure.

The main valve shall be packed with leather (or other soft material) to insure tight closure and prevent metal to metal friction and seating.

The main valve shall include a position indicator rod to show position of opening of the piston.

The main valve shall include gauge cocks for testing purposes.

The pilot valve, controlling operation of main valve, shall have a range for adjustment, be easily accessible and so arranged to allow for its removal from the main valve while the main valve is under pressure.

The pilot valve and all associated piping and fittings necessary for proper operation (except the separate static pressure sensing line if required) shall be factory assembled and furnished with the altitude valve.

Ball valves shall be installed in the control piping to completely isolate the pilot valve when conditions may require pilot isolation for maintenance or repair.

An external strainer with blow-off will be provided in the control circuit to protect the pilot and speed control valves.

The design shall be such that repairs and dismantling internally of main valve may be made without its removal from the line.

## Options

- D - The valve will be equipped with a **delayed opening feature**.
- CI - The valve will include an **Internal check feature** to prevent reverse flow through the valve.
- N - The valve will be equipped with a **speed control valve** to deal with highly specific requirements for controlling the valve closure rate on pressure reversal.
- SG - The valve will include a **3 Way solenoid pilot** to close the valve fully when the solenoid is energized.
- SF - The valve will include a **3 Way solenoid pilot** to close the valve fully when the solenoid is de-energized.
- ES - The valve will include a **higher efficiency strainer** to provide extra protection against fouling or damaging the control system.
- LS - The valve will include a **limit switch** to signal if the valve is opened or closed.

## Physical and Chemical Properties

The 125 lb. and 250 lb. flanged assemblies shall conform to ANSI standards for flange thickness and drilling and wall thickness of body and caps.

The valve shall be constructed of first class grey iron.

The grey iron shall be free from cold shuts, defective or spongy spots and conforming to ASTM specification A-126 Class B with bronze or stainless steel trim.

The bronze parts shall conform to ASTM specification B-62.  
**For sizes 4" - 12"**

The seat disc shall be bronze.

The main cup plates shall be bronze.

The main bushing shall be bronze.

### **For sizes 14" - 36"**

The seat disc shall be a cast iron center/bronze outer ring.

The main cup plates shall be bronze.

The main bushing shall be bronze.

### **For sizes 42" - 48"**

The seat disc shall be a cast steel.

The main cup plates shall be cast steel.

The main bushing shall be stainless steel.

### **For all sizes**

The external pilot valve shall be bronze

The rugged internal piston shall be bronze.

The seat ring shall be bronze.

The stem nuts shall be bronze.

The seat packing support shall be bronze.

The position indicator shall be bronze.

The bottom cap cylinder shall be bronze.

(Specifications continued on next page)

# SINGLE ACTING ALTITUDE VALVE

Specifications (continued)

Model Number: 30AWR

(Physical and Chemical Properties continued)

The piping shall be rigid brass pipe.

The strainer shall be bronze body with stainless steel screen.

The ball valves shall be full ported with stainless steel shaft, nut and adjusting handle.

The stainless steel shall be Grade 303 / 304 / 316 / CF8M / \_\_\_\_\_ .

(Option) The bottom cap cylinder shall be bronze and teflon coated. The Teflon shall be applied in two parts: Part 1 shall be a primer Teflon coating with a minimum thickness of 5 mils. Part 2 shall be a finish coat of Teflon TFE with a minimum thickness of 5 mils. for a final coat minimum thickness of 10 mils.

## Test

The test before shipment may be witnessed by a representative of the Engineers for simulated field conditions and a cold hydrostatic test of at least 100% above the maximum pressure for which the valve is to be operated.

## Painting

Ferrous surfaces of the valve shall be coated with NSF Certified Epoxy in accordance with ANSI/NSF Std. 61, and conforms to AWWA D102 Inside System No. 1.

## Reference

**The valve will be equal in all respects to the 30AWR\_\_\_\_\_ model;** as manufactured by the Ross Valve Mfg. Co., Inc., 6 Oakwood Ave., Troy, NY 12181.

**NOTE:** To indicate the basic valve with the required customized features, simply add the related codes to the basic valve number.

**Example:** The valve will be equal in all respects to the 30AWR-D model as manufactured by the Ross Valve Mfg. Co., Inc., 6 Oakwood Ave., Troy, NY 12181. (30AWR-D = 30AWR with delayed opening feature.)

### Customized Feature Codes

- D - Delayed Opening-Second Single Acting Altitude Pilot Valve
- CI - Check Feature: Internal
- N - Speed Control Valve
- SG - Solenoid Pilot Valve: 3 Way-Closes the Valve When Energized
- SF - Solenoid Pilot Valve: 3 Way-Closes the Valve When De-energized
- ES - Higher Efficiency Strainer
- LS - Limit switch

**NOTE:** The Ross Valve Mfg. Co., Inc. reserves the right to modify valve construction which will result in equal or superior performance to existing designs. These modifications may be made at any time and at the sole discretion of the manufacturer.