

PRESSURE REDUCING VALVE

Purpose: Control outlet pressure

Model Numbers: 21T - 28T



Sizes: 1/2" - 1 1/2"

Type: Direct Acting Throttling

Primarily Controlled By:

Hydraulic pressure (downstream)

Located: In line

Purpose: To prevent outlet pressure from exceeding a preset maximum level.

Body: Globe

External Piping: None

Packing: Replaceable

Inlet Pressure: Maximum: 250 psi

Inlet Pressure: Minimum: 5 psi

Construction: All bronze

Connections: Union or NPT

Control Valves: None

Basic Applications

1. Feed small lines with low flows.
2. Bypass units on larger valves to handle low flows.

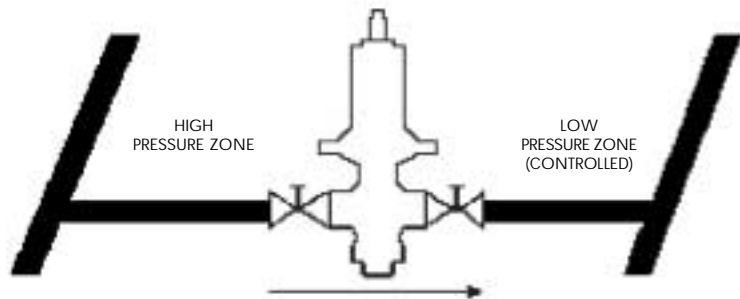

Outlet Pressure

UNION CONNECTIONS	RANGE (PSI)
Model Number: 21T	20 - 60
Model Number: 22T	40 - 150
Model Number: 23T	1 - 15
Model Number: 24T	5 - 25
NPT CONNECTIONS	RANGE (PSI)
Model Number: 25T	20 - 60
Model Number: 26T	40 - 150
Model Number: 27T	1 - 15
Model Number: 28T	5 - 25

If: Supply pressure is higher than user capacity (User's demand may include quick increases and decreases.)

Ross Valve will: Pass only the quantity of water to the user, with a minimum of shock waves, to maintain a preset lower pressure. (adjustable)

PRESSURE REDUCING VALVE

Operation Model Numbers: 21T - 28T

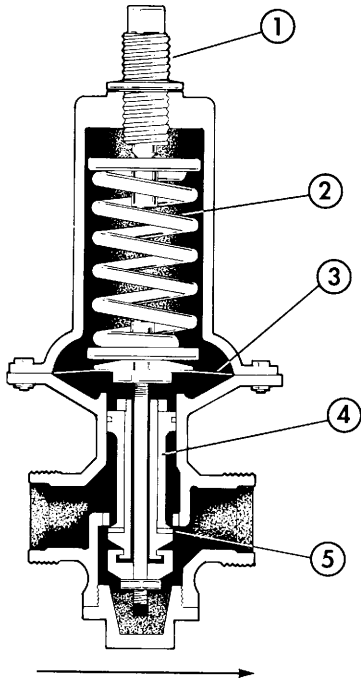

PARTS	
1	Adjusting Screen
2	Adjusting Spring
3	Diaphragm
4	Stem
5	Seat Packing

Control Unit

A straight forward control mechanism can be adjusted as pressure requirements change.

1. A diaphragm, connected to a hollow stem, is held in balance by a spring load on its top side and downstream water pressure underneath.
2. Seat packing against a seat ring, connected to the same stem, holds back the high inlet pressure.

Operation

The fundamental action of these Ross Valves allows them to provide smaller systems with a smooth flow while accurately discharging reduced downstream pressure.

1. When downstream (user) pressure increases, the
 - a. Pressure backs up into the valve, increasing pressure up through a hollow stem under the diaphragm, pushing the diaphragm up.
 - b. Seat moves up.
 - c. Valve closes accordingly.
2. When downstream (user) pressure decreases, the
 - a. Pressure under the diaphragm decreases, allowing the springload pressure above to push the diaphragm down.
 - b. Seat moves down.
 - c. Valve opens accordingly.

Cavitation

Cavitation may occur when 2 factors, a high pressure drop combined with a low outlet pressure, are present. Cavitation damage is caused by the collapse of the small cavities formed in the fluid stream during the sudden decrease in pressure. When the valve body or pipe walls confine the fluid stream and raise the pressure above the vapor pressure of the "bubbles" minute implosions occur resulting in extremely high impact forces. Where these implosions contact the valve parts, structural damage will result. If conditions for cavitation are expected, consult a Ross engineer.

Sizing

DO NOT OVERSIZE.
Ideal Operating Position: 20% to 100% open - In this position seat erosion is at a minimum and pressure control is stable.

Consult a Ross Representative

1. For recommendations if conditions for cavitation are encountered.
2. To recommend correct valve sizing.
3. About any specific requirements.

ROSS ADVANTAGE

1. Ross engineers provide in depth service based on:
 - a. state of the art technology and
 - b. the company's experience which dates back to 1879.
2. Globe body design provides most desirable characteristics for pressure reduction.
3. Throttling action of piston gives a relatively unobstructed flow at maximum flow rates.
4. Valve operates totally on hydraulic pressure. No external controls are needed
5. Valve is completely tested and adjusted in the factory.
6. Rugged construction and simple design provide a longer valve life.
7. All parts are built and manufactured in the USA.

Additional Information

Item	Page
Dimensions - Strainers	EN - 26
Head Loss Guide	EN - 2
Parts List - Strainers	EN - 42