

Sure 150 Spring Return Electric Actuator

Since 1968, RCS® has been providing the most complete line of fail-safe, spring-return electric actuators to the automation market. To further compliment and expand our industry-leading product offering, RCS® is pleased to introduce the latest model in our SurePowr® product line, the Sure 150 Spring-return electric actuator, offering the following features:

- Spring-ending torque of 1,800 inch-pounds (204 Nm), and available in either clockwise or counter-clockwise spring fail rotation. The spring is made from heat treated steel. Xylan® coated for corrosion resistance.
- Enclosure is rated for NEMA 4X and NEMA 6 environments (IP 66 and IP 67), and for NEMA 7 and NEMA 9 hazardous environments (Class I, Divisions 1 & 2, Groups C & D, and Class II, Divisions 1 & 2, Groups E, F, and G).
- Standard temperature range of -40°F to +150°F (-40°C to +65°C)
- Powder-coated enclosure and stainless steel external hardware for maximum corrosion resistance for service in the most challenging applications. Optional coatings are available for offshore or other severe conditions.
- High-visibility indicator is standard for ease of visual position monitoring.
- Thermally protected motor with Class “B” insulation standard in all models.
- Permanently lubricated geartrain eliminates the need for periodic maintenance and upkeep. Special lubricants are available for elevated or low-temperature applications.
- All gears are made from high-alloy steel, precision machined and heat treated for maximum strength and durability.
- An extensive range of control accessories are available for the Sure 150 electric actuator, including modules for analog control and network communication requirements, such as Modbus®, Profibus® DP, and DeviceNet™.



115 & 230 VAC, 1 Phase, 50/60 Hz.

Model	Output Torque Inch Pounds (N.m)	Electrical Speed of Operation — 60 Hz. (50 Hz.)	Spring Speed of Operation	Duty Cycle Rating 115 VAC	Duty Cycle Rating 220 VAC	Current Ratings 115 VAC		Current Ratings 220 VAC	
						N.L.A.*	L.R.A.*	N.L.A.*	L.R.A.*
Sure 150-15	1,800 (204)	15 seconds/90° (18 seconds/90°)	5 seconds/90° (max) +	25% (1), (2)	25% (1), (2)	1.90	2.90	.90	1.35

* (N.L.A.) — No Load Ampere (L.R.A.) — Locked Rotor Ampere (1) — Open/Close Service (2) — Open/Close or Modulating Service
 ** (CF) — Consult Factory + — Approximate, Based on Load



Outline Dimensions (Inches) — (Sure 150)

	Weight
	120 pounds/ 54.5Kg

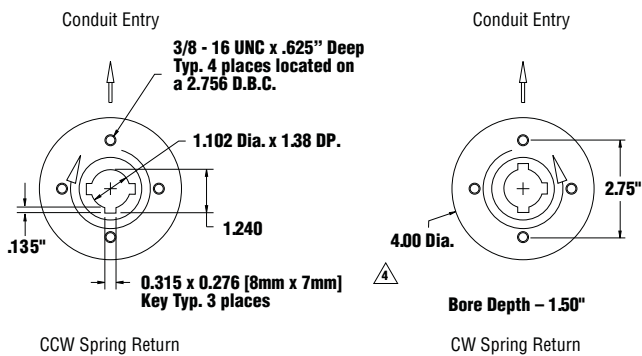
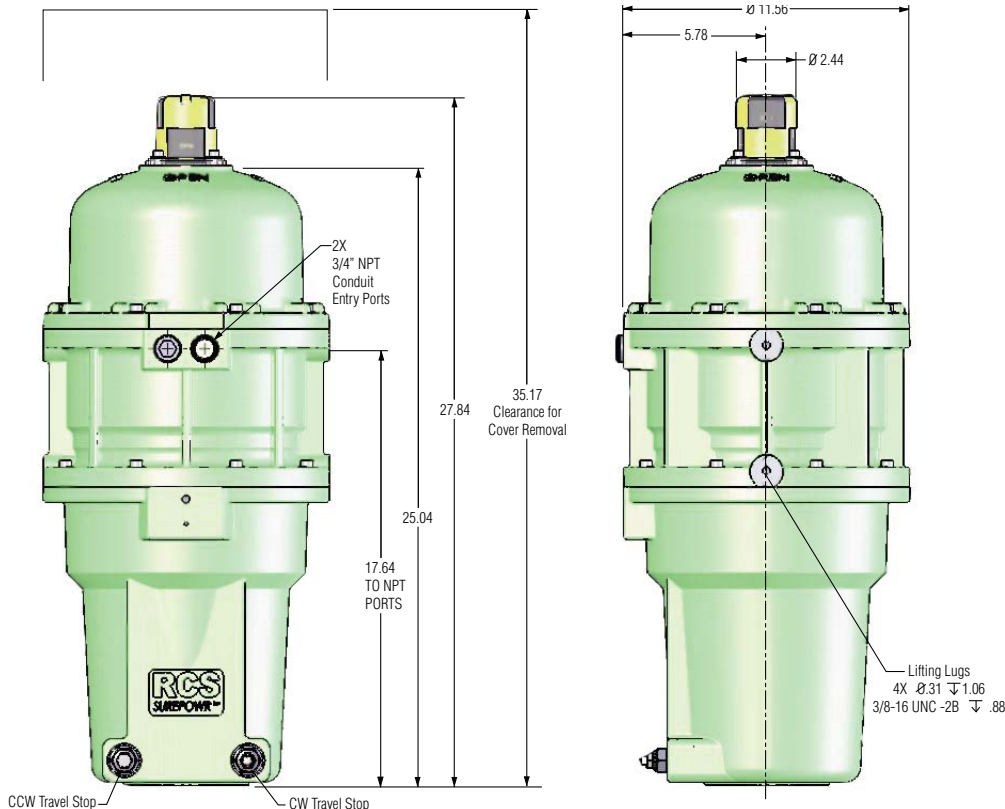

Notes

1. Direction of rotation is based on viewing actuator from top.
2. Actuator shown in power fail position.
3. Two keys are recommended for driving device.
4. Actuator suitable for mounting in any orientation.

Standard Features

- Four SPDT Limit Switches
- PTC Heater
- Motor Brake
- Position Indicator
- Adjustable Travel Stops in fail position

**Industrial Products Group
Dresser, Inc.**
16240 Port Northwest Drive
Houston Texas 77041-2645
Phone: 832.590.2306 Toll Free: 800.945.9898 Fax: 713.849.2879
www.rcsactuators.com



www.dresser.com