

Model G240 Gear Flow Meter (Analog) 2.4 to 240 liters/min

SPECIFICATIONS

Flow Range	2.4 to 240 liters/min
Maximum Operating Pressure	275 bar (4000 psi) - NPT fittings 414 bar (6000 psi) - SAE fittings
Displacement	133 cc/rev
Weight	21 kg
Recommended Filtration	30 micron
Port Size(s)	1" NPT, #16 SAE
Accuracy (at 30 cP)	± 0.3% of reading over a 100:1 turndown (30 cP)
Fluids	Most non-aqueous, hydrocarbon based fluids



MATERIALS OF CONSTRUCTION

Body	Stainless steel, type 303
Gears and Shafts	Stainless steel, type 17-4
Bearings	All ball bearings, 440C stainless steel
Seals	Viton®- standard, Teflon®, Perfluoro elastomer

ANALOG TRANSMITTER

Output Signal	Any range of ± 10V or ± 20mA Linearized and damped with anti-dither protection. Accurate to 2mV or 4µA
Power Supply Requirements	Two Models - 12Vdc@ 90 mA, 24Vdc@ 45 mA
Ambient Operational Range	-40°C to 75°C
Metered Liquid Temp Range	-40°C to 90°C, standard model -40°C to 200°C, ultra high temperature model
Compliance	CE Certified

CONNECTIVITY/DIMENSIONS

Turck® Connector		
Mating Cable Wire Color	Pin #	
Case Ground	Blue	3
Common	Black	4
Power *	Brown	1
Signal Output (+)	Grey	5
Signal Output (-)	White	2

* Please specify 12Vdc or 24Vdc operation

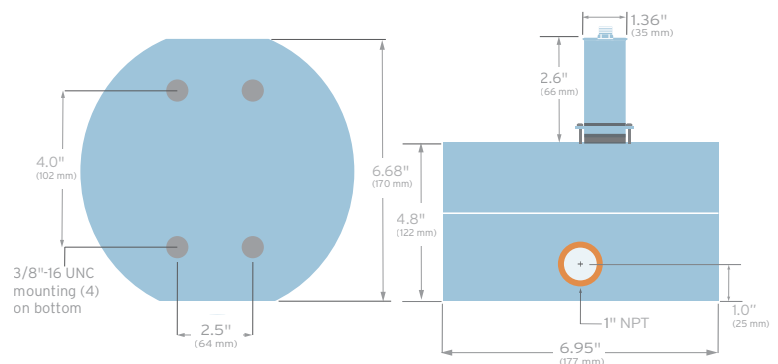

Model G240 Flow Meter (Analog)

ACCURACY (Sample Curves)

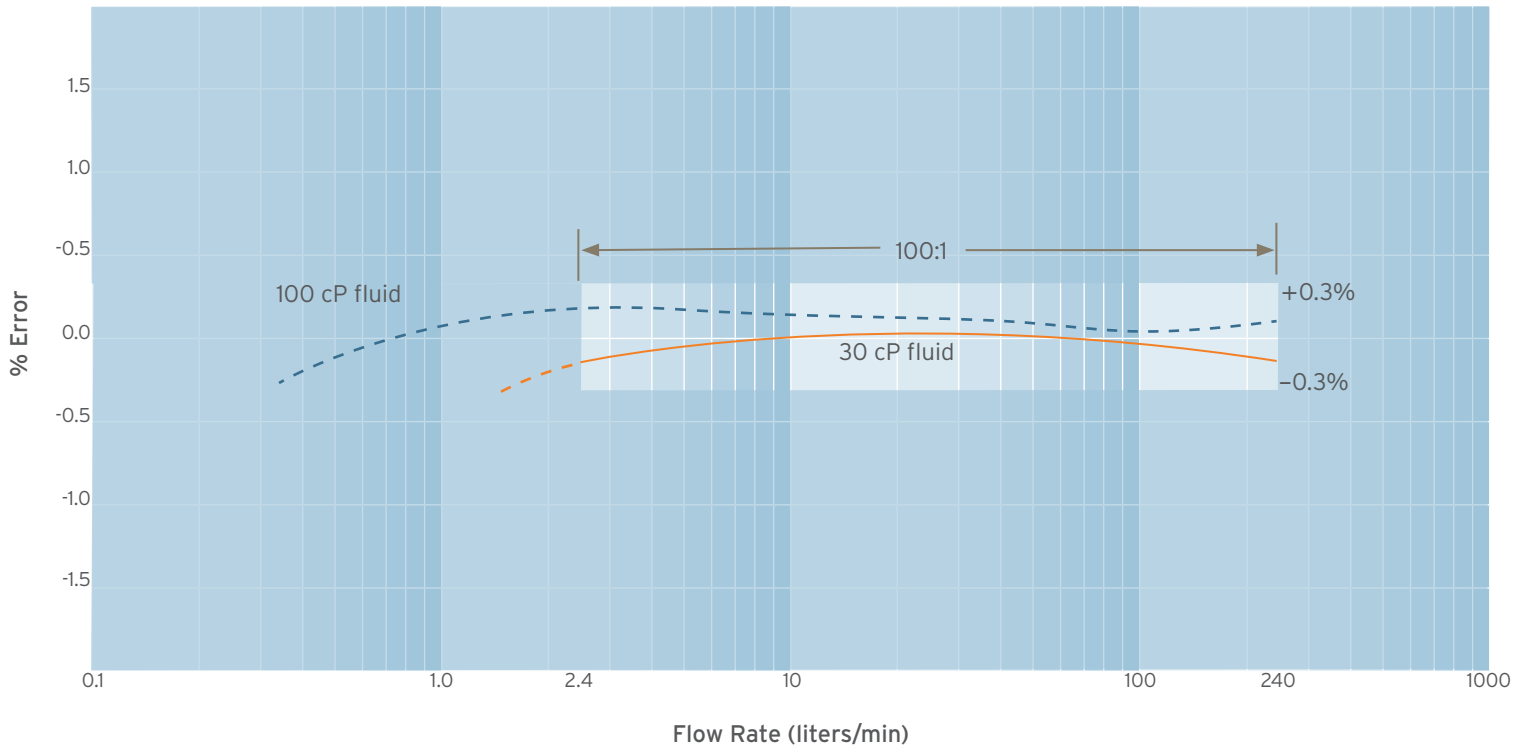

TYPICAL PRESSURE DROP

