

## Model G004 Gear Flow Meter (Frequency) 0.04 to 4 liters/min

### SPECIFICATIONS

Flow Range	0.04 to 4 liters/min.
Maximum Operating Pressure	414 bar (6000 psi)
Displacement	1.8 cc/rev
Weight	1.1 kg
Recommended Filtration	15 micron
Port Size(s)	1/8" NPT or #4 SAE
Accuracy (at 30 cP)	± 0.3% of reading over a 100:1 turndown (30 cP)
Fluids	Most non-aqueous, hydrocarbon based fluids

### MATERIALS OF CONSTRUCTION

Body	Stainless steel, type 303
Gears and Shafts	Stainless steel, type 17-4
Bearings	All ball bearings, 440C stainless steel
Seals	Viton®- standard, Teflon®, Perfluoro elastomer

### FREQUENCY TRANSMITTER

Output Signal	5 Vdc square wave (TTL and CMOS compatible)
Output Resolution	Selectable: 1-1000 pulses/rev (5 -555 pulses/cc)
Min-max frequency	0 - 60 KHz
Power Supply Requirements	5 - 26 Vdc, @ 30 mA
Ambient Operational Range	-40°C to 80°C
Metered Liquid Temp Range	-40°C to 90°C, standard model
(using 5 Vdc power)	-40°C to 160°C, high temperature model
	-40°C to 232°C, ultra high temperature model
Compliance	CE Certified

### CONNECTIVITY/DIMENSIONS

Turck® Connector		
Mating Cable Wire Color	Pin #	
Case Ground	Blue	3
Common	Black	4
Power (+5-26Vdc)	Brown	1
Pulse Output	White	2
N/A	Grey	5

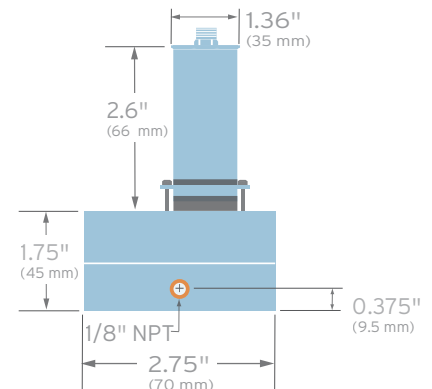
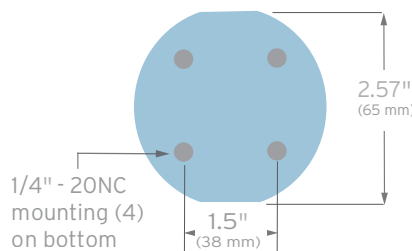

# Model G004 Flow Meter

## ACCURACY (Sample Curves)

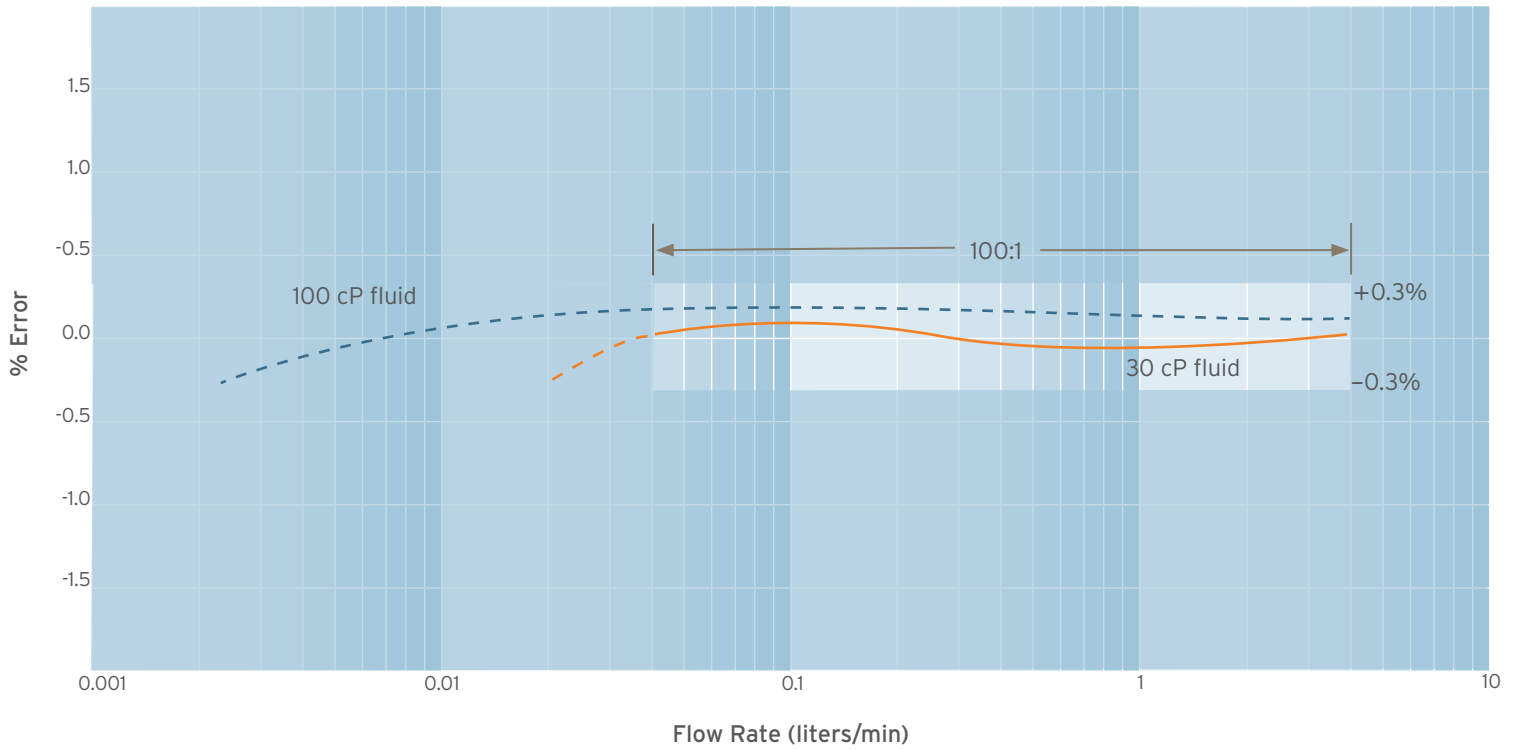

## TYPICAL PRESSURE DROP

