



Max Machinery, Inc.

Model G004 Gear Flow Meter (Analog) 0.04 to 4 liters/min

SPECIFICATIONS

Flow Range	0.04 to 4 liters/min.
Maximum Operating Pressure	414 bar (6000 psi)
Displacement	1.8 cc/rev
Weight	1.1 kg
Recommended Filtration	15 micron
Port Size(s)	1/8" NPT or #4 SAE
Accuracy (at 30 cP)	± 0.3% of reading over a 100:1 turndown (30 cP)
Fluids	Most non-aqueous, hydrocarbon based fluids



MATERIALS OF CONSTRUCTION

Body	Stainless steel, type 303
Gears and Shafts	Stainless steel, type 17-4
Bearings	All ball bearings, 440C stainless steel
Seals	Viton®- standard, Teflon®, Perfluoro elastomer

ANALOG TRANSMITTER

Output Signal	Any range of ± 10V or ± 20mA Linearized and damped with anti-dither protection. Accurate to 2mV or 4µA
Power Supply Requirements	Two Models - 12Vdc@ 90 mA, 24Vdc@ 45 mA
Ambient Operational Range	-40°C to 75°C
Metered Liquid Temp Range	-40°C to 90°C, standard model -40°C to 205°C, ultra high temperature model
Compliance	CE Certified

CONNECTIVITY/DIMENSIONS

Turck® Connector		
Mating Cable Wire Color	Pin #	
Case Ground	Blue	3
Common	Black	4
Power *	Brown	1
Signal Output (+)	Grey	5
Signal Output (-)	White	2

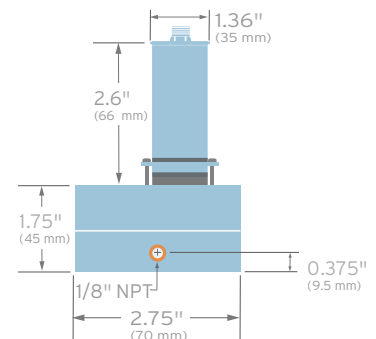
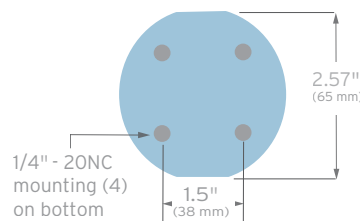

* Please specify 12Vdc or 24Vdc operation

Model G004 Flow Meter (Analog)

ACCURACY (Sample Curves)

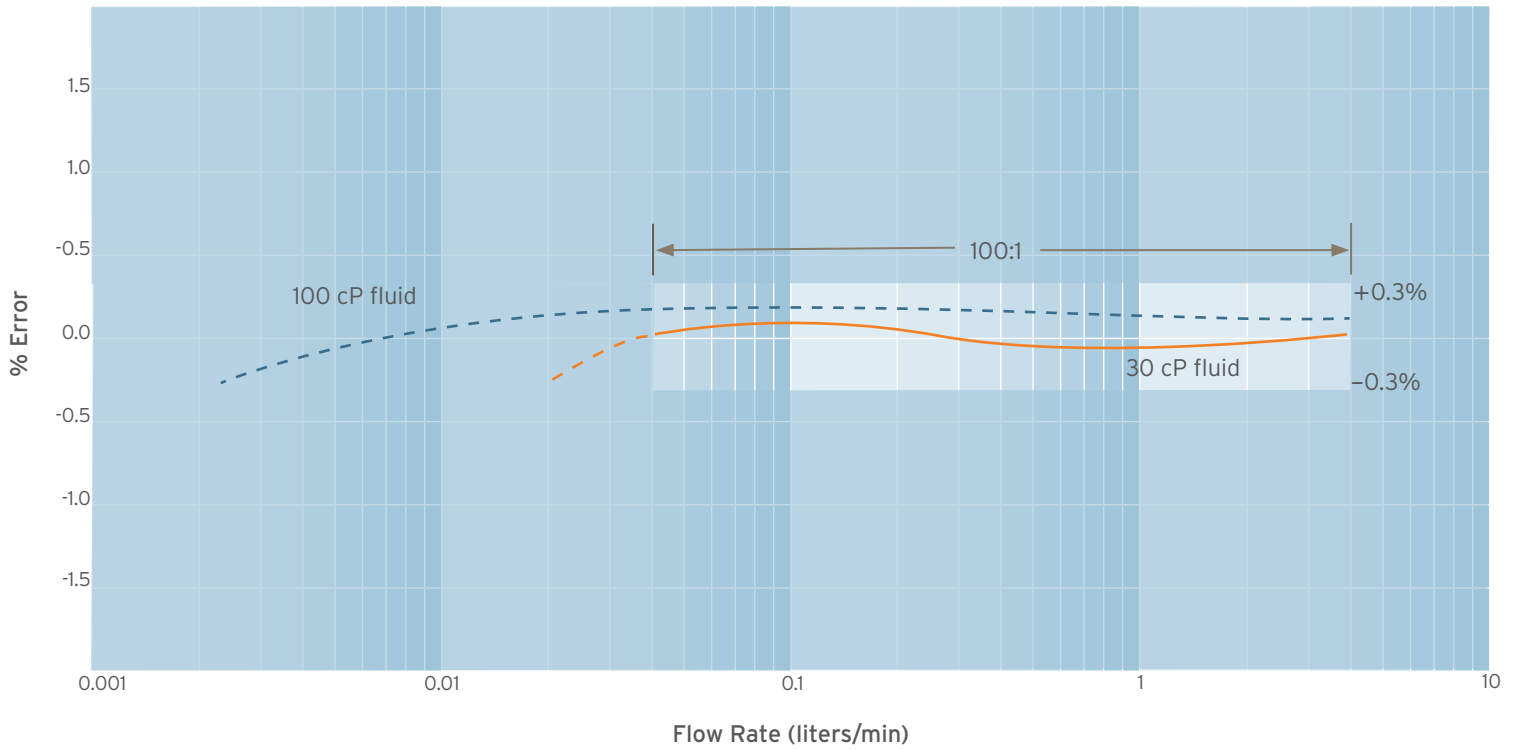

TYPICAL PRESSURE DROP

