

Modular Housings

Knick >

VariTrans® P 27000



The “Multimeter” among the isolators. With 480 switchable calibrated ranges and broad-range power supply.

The Task

A wide range of measuring signals need to be galvanically isolated and converted into standard signals. This applies to any input signals in the range ± 20 mV to ± 200 V and from ± 0.1 mA to ± 100 mA.

The Problem

The variety of tasks results in a large number of different devices.

The Solution

The calibrated switching of the input and output ranges using DIP switches allow the Knick VariTrans® P 27000 professional universal isolators to be used without complicated readjustment. As switchover occurs without expensive and unreliable equipment, the devices can also be easily configured on site. The broad-range power supply for all common supply voltages from 20 to 253 V AC/DC offers maximum flexibility.

To make setting the required input and output ranges simple and user friendly, we supply a free software tool called VariSoft® to support the user. VariSoft® shows you the correct DIP switch position when you enter the required input and output ranges and it has a print option for your documentation. You can download VariSoft® free of charge from our website.

The Housing

At just 12.5 mm wide, the modular housing with pluggable screw terminals allows simple and fast assembly and prewiring of enclosures. Housings with fixed screw terminals are also available for extremely high mechanical loads.

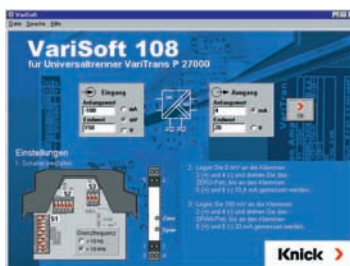

The easy-to-open housing allows simple configuration of the input and output ranges and provides good protection against contact and unintentional adjustment.

The Advantages

The analog transmission of the measurement signal with transformer potential isolation and the digitally controlled range selection guarantee almost perfect signal transmission:

- Gain error only 0.08 %
- Excellent pulse formation
- Extremely low residual ripple
- Maximum long-term stability and reliability

The Technology

A microcontroller monitors the control element settings and controls the calibrated range selection. Interference to the signal transmission – for example, due to contact resistance in the range switch – is thus ruled out.

Thanks to the VariPower® power supply, the devices can be used all over the world with almost any power supply. The extremely low power consumption and the related minimal self-heating significantly increase reliability. The consequence: a 5-year warranty.

**Warranty
5 years!**

Defects occurring within 5 years from delivery are remedied free of charge at our works (carriage and insurance paid by sender).

Universal Isolation Amplifiers

Isolation Amplifiers
Transmitters

Indicators

Process Analytics

Portable Meters

Laboratory Meters

Sensors

Fittings



Knick >

■ The Facts

Flexible and highly accurate

Calibrated range selection without complicated readjustment

VariPower®

broad-range power supply,
20 ... 253 V AC/DC

Extremely compact design

12.5 mm modular housing,
up to 80 active isolators per
meter of mounting rail

Fast and easy configuration

Housing simple to open

Pluggable screw terminals

Simple, time-saving assembly and
prewiring of enclosures

3-port isolation

Protection against incorrect
measurements or damage

Maximum accuracy

Individual test report

following EN 10204 2.3

Safe isolation

according to EN 61140.
Protection against high voltages
(for example, with shunt meas-
urements at high potentials or in
3-phase systems).

Maximum reliability

No repair and failure costs

5-year warranty

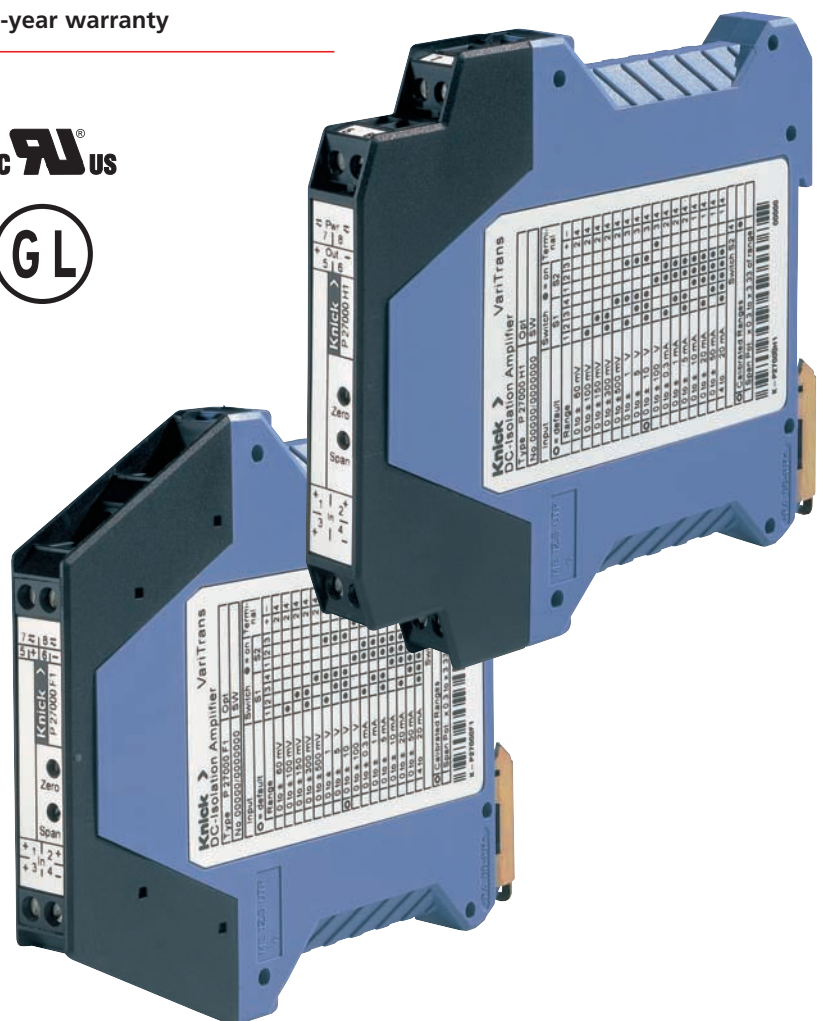

Modular Housings

VariTrans® P 27000

■ Product Line

Devices			Order No.	Order No.
	Input	Output	With pluggable screw terminal	With fixed screw terminal
VariTrans® P 27000 Input and output adjustable	0 ... ±20 mV/200 V 0 ... ±0.1 mA/100 mA	0 ... 20 mA 4 ... 20 mA 0 ... 10 V 0 ... ±10 V 0 ... ± 20 mA	P 27000 H1	P 27000 F1
VariTrans® P 27000 Fixed setting	0 ... ± 20 mA 0 ... ± 20 mA 0 ... ±60 mV 0 ... 60 mV 0 ... ±60 mV 0 ... ±150 mV 0 ... 150 mV 0 ... ±150 mV 0 ... ±300 mV 0 ... 300 mV 0 ... ±300 mV 0 ... ±500 mV 0 ... 500 mV 0 ... ±500 mV 0 ... ±1 V 0 ... 1 V 0 ... ±1 V 0 ... ±10 V 0 ... ±10 V	0 ... ± 20 mA 0 ... ±10 V 0 ... ± 20 mA 4 ... 20 mA 0 ... ±10 V 0 ... ± 20 mA 4 ... 20 mA 0 ... ±10 V 0 ... ± 20 mA 4 ... 20 mA 0 ... ±10 V 0 ... ± 20 mA 4 ... 20 mA 0 ... ±10 V 0 ... ± 20 mA 4 ... 20 mA 0 ... ±10 V 0 ... ± 20 mA 0 ... ±10 V 0 ... ± 20 mA 0 ... ±10 V	P 27016 H1 P 27018 H1 P 27056 H1 P 27057 H1 P 27058 H1 P 27066 H1 P 27067 H1 P 27068 H1 P 27076 H1 P 27077 H1 P 27078 H1 P 27086 H1 P 27087 H1 P 27088 H1 P 27096 H1 P 27097 H1 P 27098 H1 P 27036 H1 P 27038 H1	P 27016 F1 P 27018 F1 P 27056 F1 P 27057 F1 P 27058 F1 P 27066 F1 P 27067 F1 P 27068 F1 P 27076 F1 P 27077 F1 P 27078 F1 P 27086 F1 P 27087 F1 P 27088 F1 P 27096 F1 P 27097 F1 P 27098 F1 P 27036 F1 P 27038 F1
VariTrans® P 27000 Fixed setting to customer requirement			P 27000 H1-nnnn	P 27000 F1-nnnn
Power supply				
20 ... 253 V AC/DC				

Universal Isolation Amplifiers

Isolation Amplifiers
Transmitters

Indicators

Process Analytics

Portable Meters

Laboratory Meters

Sensors

Fittings

Knick 

■ Specifications

Input data

Inputs	P 27000 H1/F1:	Factory setting ± 10 V	
	Voltage	Configurable from 20 mV ... 200 V and switchable in calibrated steps: 60 mV, 100 mV, 150 mV, 300 mV, 500 mV, 1 V, 5 V, 10 V, 100 V, unipolar/bipolar	
	Current	Configurable from 0.1 mA ... 100 mA and switchable in calibrated steps: 1 mA, 5 mA, 10 mA, 20 mA, 50 mA, unipolar/bipolar and 4 ... 20 mA ¹⁾	
Input resistance	Current input	Ranges ≤ 5 mA	approx. 100 ohms
		Ranges > 5 mA	approx. 5 ohms
	Voltage input		approx. 1 Mohm
Overload	Current input	Ranges ≤ 5 mA	≤ 100 mA
		Ranges > 5 mA	≤ 300 mA
	Voltage input	Ranges ≤ 500 mV	limited by suppressor diode 36 V, max. permitted continuous current ≤ 20 mA
		Ranges > 500 mV	limited by suppressor diode 250 V, max. permitted continuous current ≤ 3 mA

Output data

Output	P 27000 H1/F1: factory setting ± 10 V 20 mA, 5 V, 10 V unipolar/bipolar and 4 ... 20 mA, 1 ... 5 V and 2 ... 10 V, calibrated selection		
Offset	-100 %, -50 %, 0 %, 50 %, 100 % of span of the selected output range calibrated selection		
Load	With output current	≤ 12 V (600 ohms at 20 mA)	
	With output voltage	≤ 10 mA (1 kohm at 10 V) ²⁾	
Offset	20 μ A or 10 mV		
Residual ripple	< 10 mV _{rms}		

Transmission behavior

Adjustment range of ZERO potentiometer	± 25 % span of selected output range		
Adjustment range of SPAN potentiometer	0.33 ... 3.30 x end value of selected input range (max. $V_{in} = 200$ V)		
Gain error	< 0.08 % meas. val. (DC)		
Cut-off frequency	P 27000 H1/F1: > 10 kHz, < 10 Hz, switchable -3 dB, fixed-setting models > 10 kHz, -3 dB		
Temperature coefficient ³⁾	< 0.005 %/K full scale (reference temperature 23 °C)		

1) Input 4 ... 20 mA: Offset switching not calibrated

2) Higher output load on request

3) Average TC in specified operating temperature range -10 °C ... +70 °C

Universal Isolation Amplifiers

Isolation Amplifiers
Transmitters

Indicators

Process Analytics

Portable Meters

Laboratory Meters

Sensors

Fittings

Knick 

■ Block Diagram

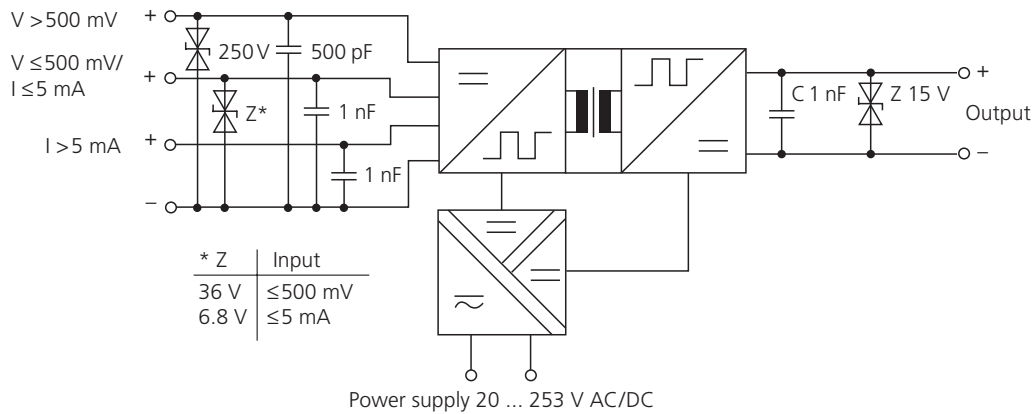

■ Application Examples

Electrical isolation

for safe coupling of the measurement signals to the evaluation electronics

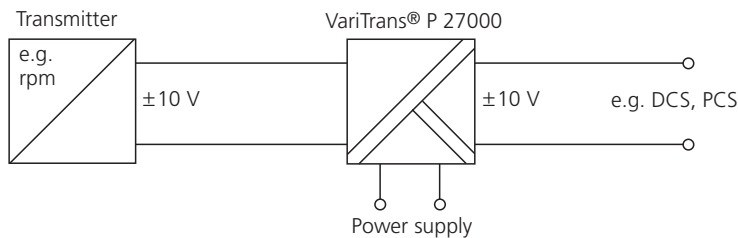

Signal conversion or range adaptation

for conversion of any measurement signals into 10 V or 20 mA standard signals

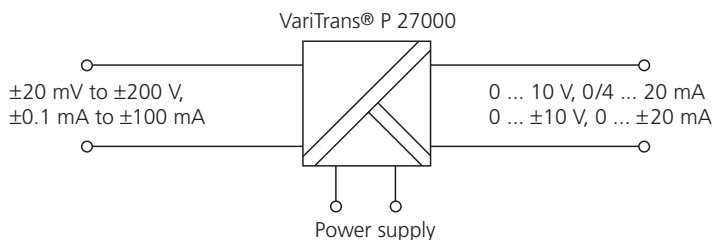

Modular Housings

VariTrans® P 27000

Application Examples (continued)

Simple shunt measurement

e.g. also with any overload range setting

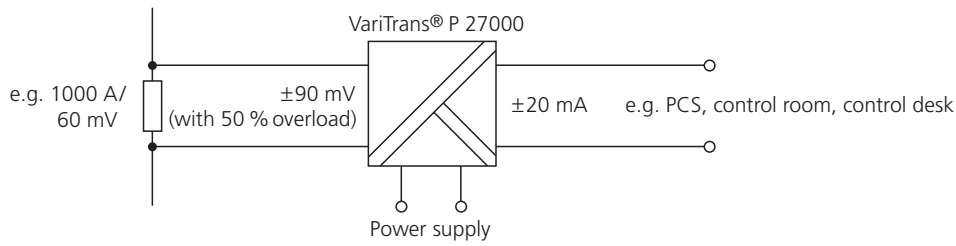

Electrical isolation

for safe coupling of the measurement signals to the evaluation electronics

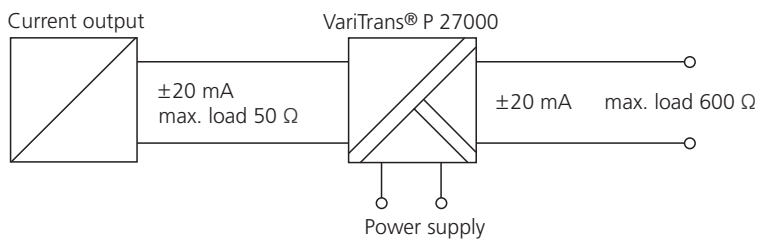

■ Dimension Drawings and Terminal Assignments

Housing with pluggable screw terminals

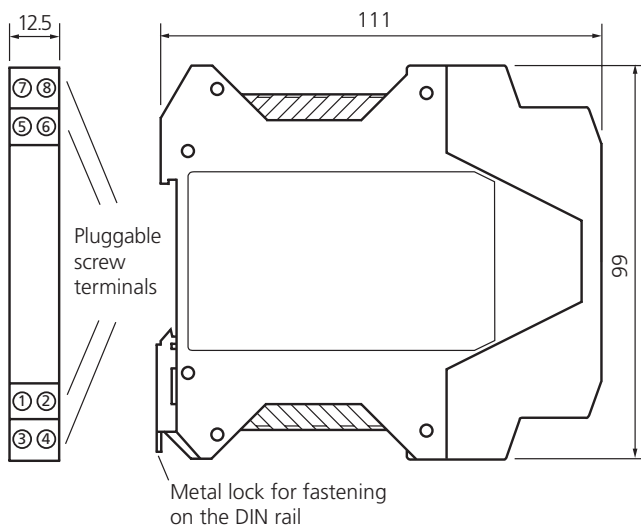

Dimension Drawings and Terminal Assignments (continued)

Housing with fixed screw terminals

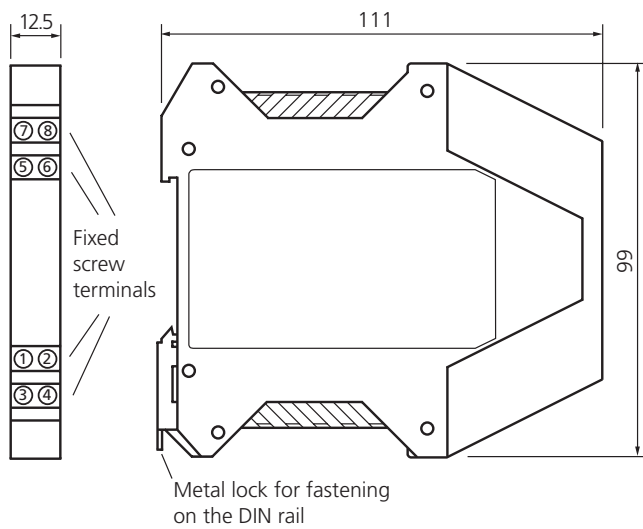

Terminal Assignments

- | | |
|--|------------------|
| 1 Input + Current >5 mA | 5 Output + |
| 2 Input + Current ≤5 mA, voltage ≤500 mV | 6 Output - |
| 3 Input + Voltage >500 mV | 7 Power supply ≈ |
| 4 Input - | 8 Power supply ≈ |

Conductor cross-section max. 2,5 mm²

Multi-wire connection max. 1 mm² (two wires with same cross-section)

All dimensions in mm!