

Modular Housings

Knick >

IsoTrans® 41

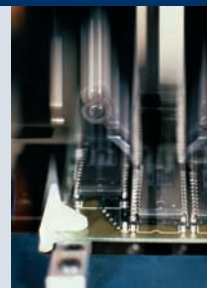

For isolation of 0(4) ... 20 mA standard current signals; up to 3 channels.

The Task

If there is no power supply available, the galvanic isolation of 0(4) ... 20 mA standard current signals requires investment in power supply units.

The Problems

Many products provide loop-powered isolation with insufficient accuracy only. The desire for high accuracy demands an isolator concept that fulfils the highest expectations.

The load capability of the 20-mA source is limited and therefore requires economical handling of the load voltage.

The Solution

Knick IsoTrans® 41 with transformer potential isolation has specifications well beyond other loop-powered DC isolation amplifiers. 0.2 % fault class and just 1.2 V voltage requirement allow diverse uses of this isolator.

The Housing

The A2 modular housing with a width of 22.5 mm for max. 3 isolators offers optimum space usage in multichannel mode. The A3 modular housing for one isolator is just 17.5 mm wide.

The full encapsulation guarantees a high level of reliability even in extreme conditions.

The Advantages

The galvanic isolation in the IsoTrans® 41 is achieved using a passive isolator that obtains its power as a voltage drop from the measurement signal. This saves on supply units and cabling and increases the reliability accordingly.

The Technology

The units work with a serial chopper generator in the current path. This avoids the accuracy-reducing current losses of normal parallel connected generators, considerably reduces the voltage drop, and ensures accurate transmission even of the lowest currents.

The Application

Galvanic isolation

- of input and output circuits
- the supply voltage of 2-wire transmitters
- in the case of addition or another coupling of signals at different potentials
- for removal of double ground compensation currents
- when there is an insufficient insulation and test voltage
- of high-potential signal sources
- for battery-powered devices with a central battery

Warranty
5 years!

Defects occurring within 5 years from delivery are remedied free of charge at our works (carriage and insurance paid by sender).

Loop-Powered Isolators for Standard Signals

Isolation Amplifiers
Transmitters

Indicators

Process Analytics

Portable Meters

Laboratory Meters

Sensors

Fittings



Knick >

■ The Facts

Loop-powered

No mains influences

Extremely high accuracy

Broad field of application

Current transmission
from 2 μ A to 50 mA

Maximum reliability

No unnecessary heat and
therefore maximum service life of
components

Negligible loading of the measurement signal

Voltage drop just 1.2 V

Low signal delay

Space-saving due to multichannel variants

Modular housing with up to
three channels

Computer-controlled testing guarantees quality

5-year warranty

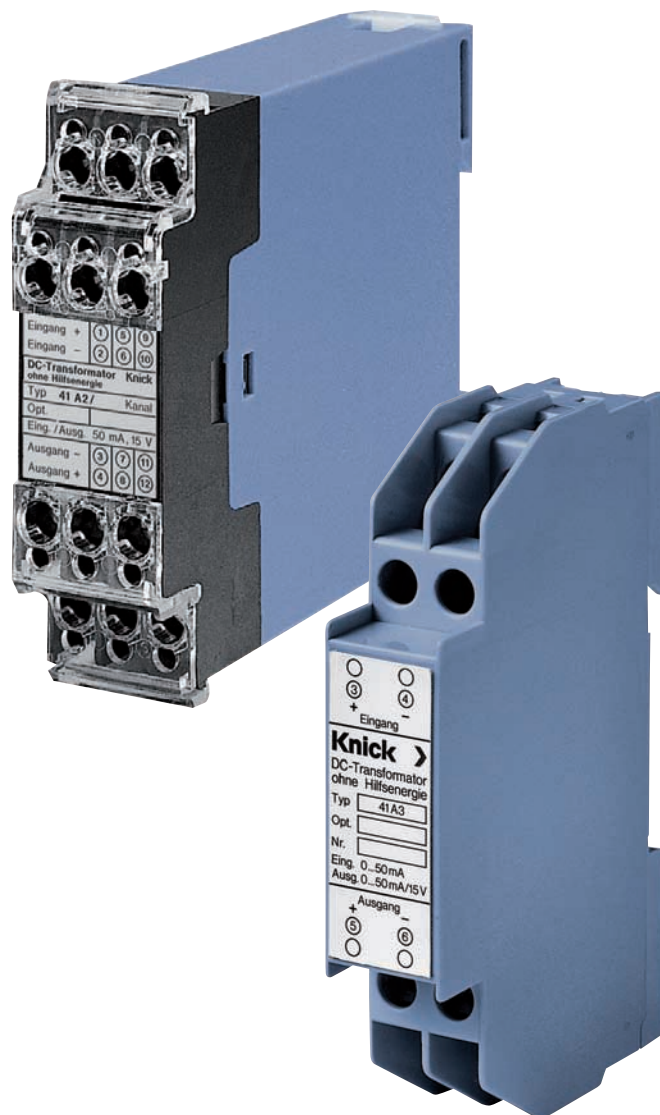

Modular Housings

IsoTrans® 41

■ Product Line

Devices		Order No.
IsoTrans® 41	1-channel, A2 modular housing (width: 22.5 mm) 2-channel, A2 modular housing (width: 22.5 mm) 3-channel, A2 modular housing (width: 22.5 mm) 1-channel, A3 modular housing (width: 17.5 mm)	41 A2 / 1 41 A2 / 2 41 A2 / 3 41 A3

Power supply

None, supply from input signal

■ Specifications

Input data

Inputs 0(4) ... 20 mA
0 ... 50 mA

Operating current < 2 μ A

Voltage drop Approx. 1.2 V (20 mA)
Approx. 1.6 V (50 mA)

Overload 100 mA, 20 V (see also page 84)

Output data

Output 0(4) ... 20 mA/max. 15 V (corresponds to 750 ohms load)
0 ... 50 mA/max. 15 V (corresponds to 300 ohms load)

Offset < 5 μ A

Residual ripple¹⁾ < 1.5 mV_{pp}/mA

Transmission behavior

Transformation error²⁾ 0.02 % meas. val.

Load error < 0.02 % meas. val. per 100 ohms

Rise or fall time Approx. 2.5 ms at 500 ohms load resistance

1) Slightly increased residual ripple can occur when load < 5 ohms

2) Temperature range -10 ... +70 °C

Loop-Powered Isolators for Standard Signals

Isolation Amplifiers
Transmitters

Indicators

Process Analytics

Portable Meters

Laboratory Meters

Sensors

Fittings

Knick 

Specifications (continued)

Isolation

Test voltage	2.5 kV AC
Working voltage (basic insulation)	500 V DC across any inputs and outputs with overvoltage category II and pollution degree 3 according to EN 61010-1 (with model 41 A2/3 across neighboring inputs and outputs, with pollution degree 2 inside the housing, degree 3 outside). For applications with high working voltages, you should ensure there is sufficient spacing or isolation from neighboring devices and protection against electric shocks.

Standards and approvals

Surge withstand	5 kV, 1.2/50 μ s, according to IEC 255-4
Immunity to interference	8 kV according to IEC 801-2

Other data

Ambient temperature	-25 ... +80 °C
Design	A2 modular housing, 22.5 mm wide, A3 modular housing, 17.5 mm wide, see dimension drawings for further measurements
Ingress protection	Protection class with terminal cover according to DIN 40050: Housing IP 40, terminals IP 20
Mounting	Snap-on mounting for 35 mm top hat rail according to EN 50022 or M4 screw mounting See dimension drawings for conductor cross section
Weight	41 A2 / 1: Approx. 140 g 41 A2 / 2: Approx. 190 g 41 A2 / 3: Approx. 210 g 41 A3: Approx. 70 g

Modular Housings

IsoTrans® 41

■ Transfer Function

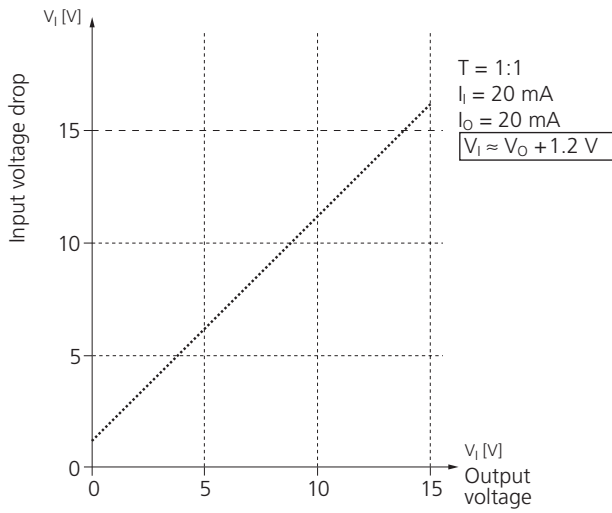

■ Reactions to Square Step of Input Current

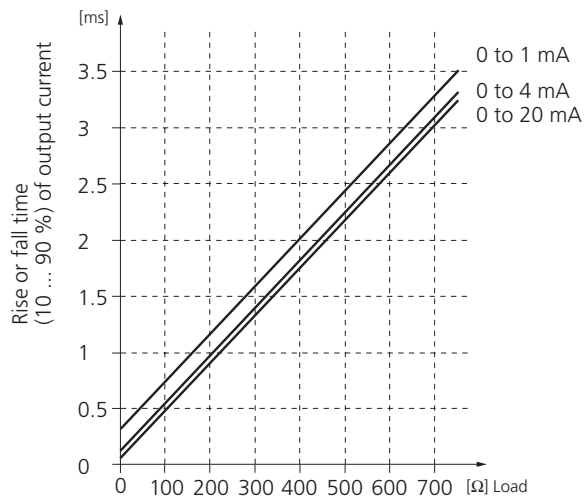

Loop-Powered Isolators for Standard Signals



■ Block Diagram

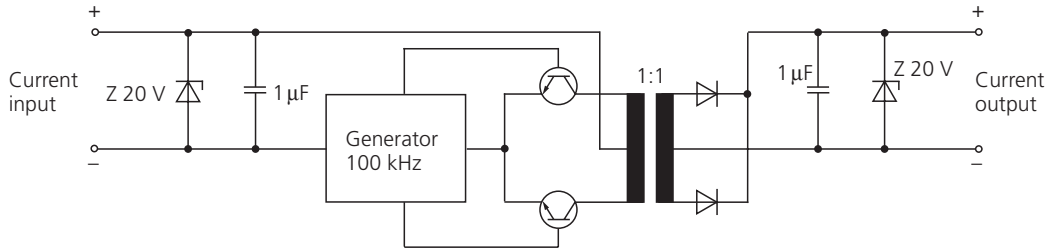

■ Application Examples

Electrical isolation

with impressed current, current output

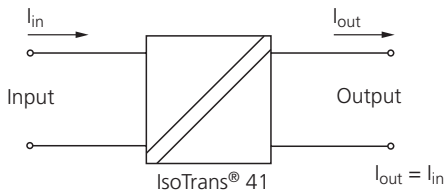

Electrical isolation

with impressed input current, voltage output

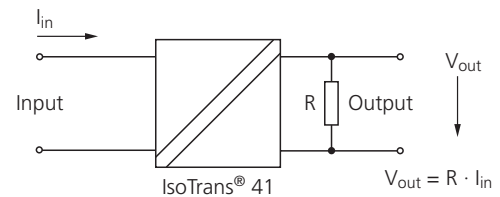

Electrical isolation

in two-wire technology

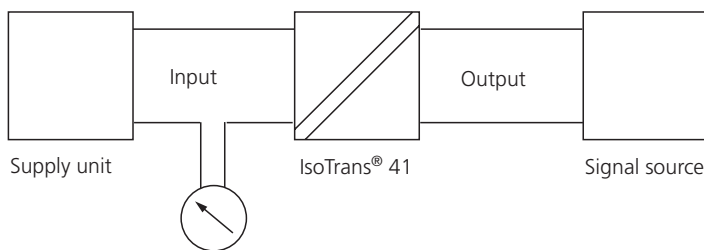

Modular Housings

IsoTrans® 41

Application Examples (continued)

Electrical isolation

for current addition with impressed currents

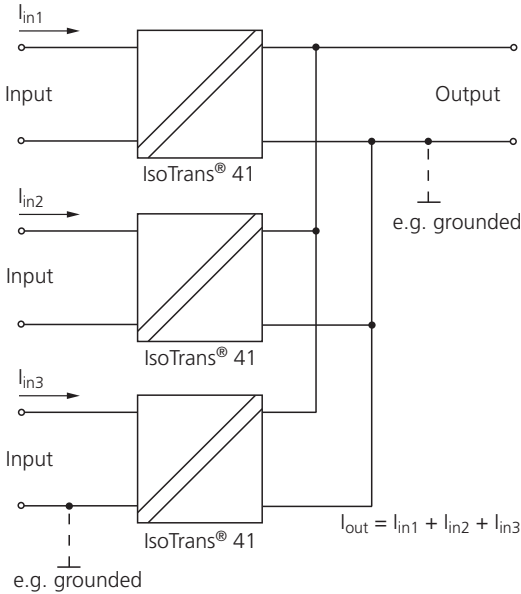

Loop-Powered Isolators for Standard Signals

Isolation Amplifiers
Transmitters

Indicators

Process Analytics

Portable Meters

Laboratory Meters

Sensors

Fittings

Knick 

■ Dimension Drawings and Terminal Assignments

Type A2 Modular Housing

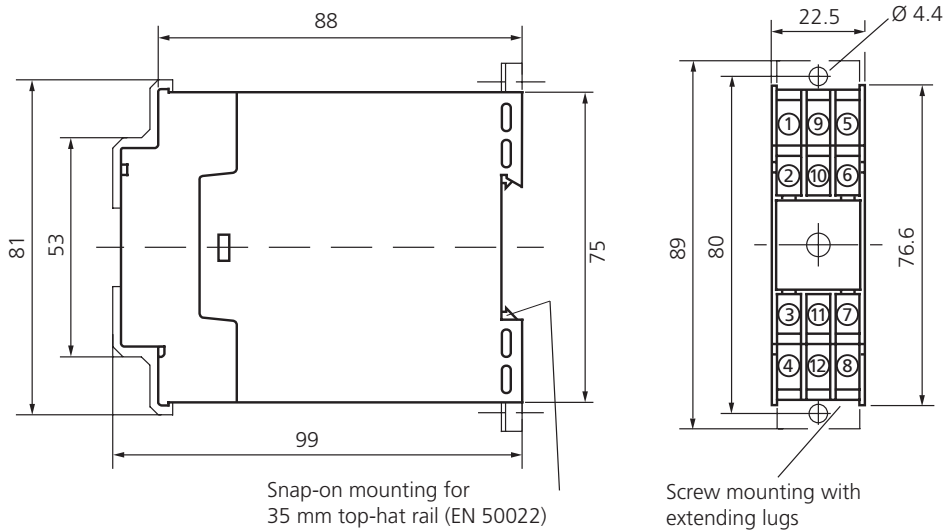

Channel 1	1 Input	+	Channel 2	5 Input	+	Channel 3	9 Input	+
	2 Input	-		6 Input	-		10 Input	-
	3 Output	-		7 Output	-		11 Output	-
	4 Output	+		8 Output	+		12 Output	+

M 2.5 x 8 connecting screws with self-releasing clamping pieces, max. conductor cross-section 2 x 2.5 mm² solid or 2 x 1.5 mm² stranded wire with ferrule

Type A3 Modular Housing

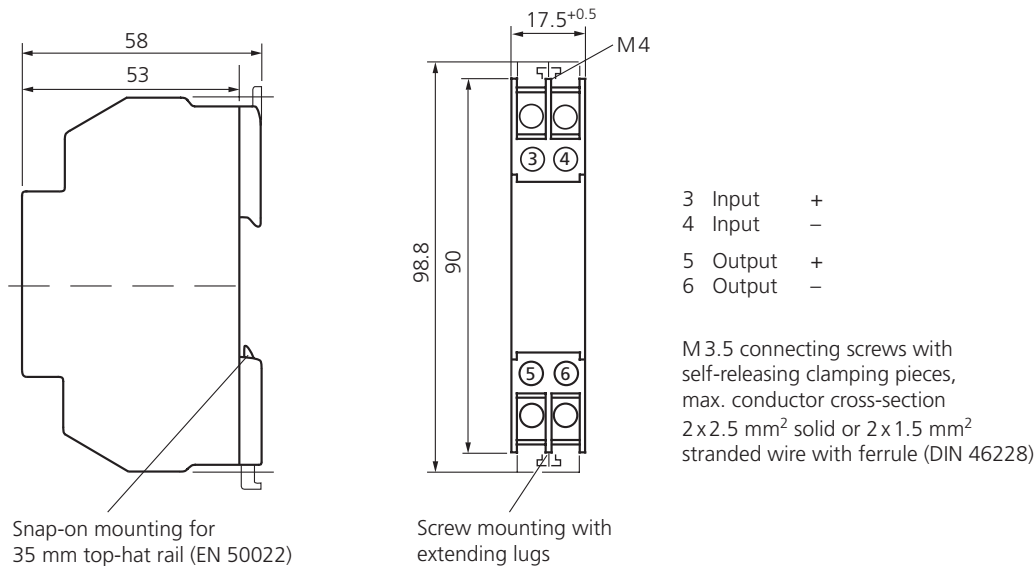

All dimensions in mm!

Modular Housings

Knick >

IsoTrans® A 47



**For isolation of
0(4) ... 20 mA standard
signals, up to 4 channels.**

The Task

Guaranteeing reliable and safe system operation requires galvanic isolation between sensors and controller (e. g. PCS or DCS).

The Problems

are often, particularly in large plants, the lack of space for mounting the isolators and the increasing operating temperatures in distributors and enclosures.

The Solution

comes in the form of the Knick Advanced Series IsoTrans® A 47 loop-powered isolators. An extremely high component density of 177 channels per meter mounting rail and excellent technical properties, such as their safe isolation, make the isolators unbeatable!

The Housing

The modern modular housings with a width of 12.5 mm for one or two channels and 22.5 mm width for four channels with practical plug-in terminals allow simple and quick assembly or prewiring of the enclosure.

The Function Principle

The IsoTrans® A 47 obtains its power as a voltage drop directly from the measurement signal without falsifying it. There are no costs for a power supply and wiring.

The IsoTrans® A 47 has virtually no self-heating that would cause the electronic components to age faster. Together with a patented switching technique, this means maximum reliability. Due to this extraordinary long service life: a 5-year warranty!

The Technology

A transmission error of just 0.1 %, excellent square-wave response and very low residual ripple guarantee perfect signal transmission. The low voltage drop of approx. 2.5 V only loads the signal slightly.

The high test voltage up to 4 kV and Safe Isolation up to 300 V according to EN 61140 protect operating personnel against the mains voltage, for example.

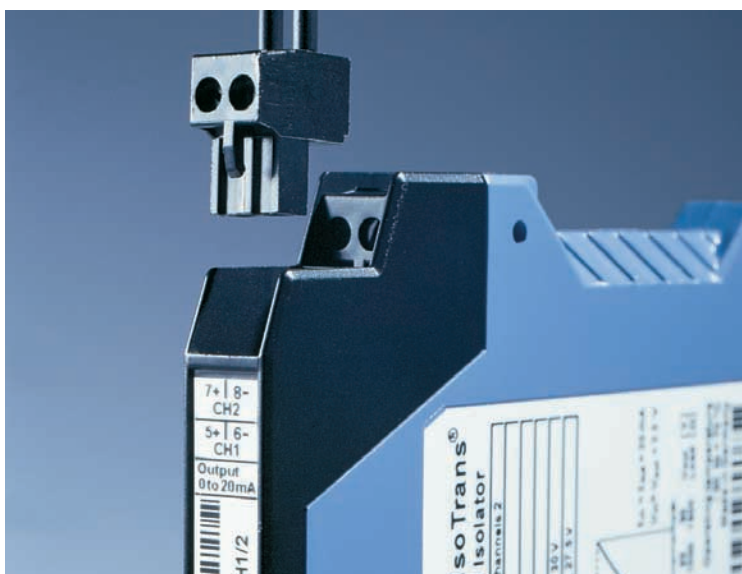

Loop-Powered Isolators for Standard Signals

Isolation Amplifiers
Transmitters

Indicators

Process Analytics

Portable Meters

Laboratory Meters

Sensors

Fittings



Knick >

■ The Facts

Extremely compact design

Up to 177 channels per meter

1-, 2-, and 4-channel versions

Cheap and flexible for a wide range of applications

Practical screw terminals

Simple, time-saving assembly and prewiring of enclosures

Galvanic isolation between input and output

Protection against incorrect measurements or damage to the equipment due to parasitic voltages

No power supply required

Cost savings due to lower wiring requirement, no mains influences, no unnecessary heating and therefore maximum service life of components

High accuracy

No distortion of the measurement signal

Maximum reliability

No repair and failure costs

5-year warranty

RA®
us

Warranty
5 years!

Defects occurring within 5 years from delivery are remedied free of charge at our works (carriage and insurance paid by sender).

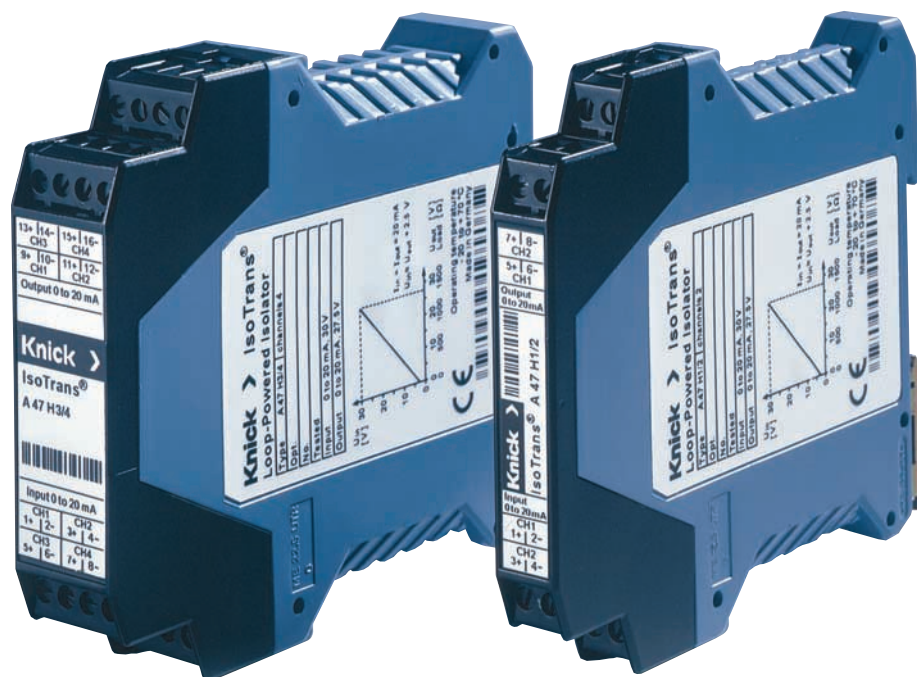

Modular Housings

IsoTrans® A 47

■ Product Line

Devices		Order No.
IsoTrans® A 47	1-channel, H1 modular housing (width: 12.5 mm) 2-channel, H1 modular housing (width: 12.5 mm) 4-channel, H3 modular housing (width: 22.5 mm)	A 47 H1 / 1 A 47 H1 / 2 A 47 H3 / 4
Power supply	None, supply from input signal	
Options	Increased test voltage 4 kV AC, Safe Isolation	506

■ Specifications

Input data

Input	0(4) ... 20 mA/max. 30 V (linear transmission up to 50 mA)
Operating current	< 20 μ A
Voltage drop	Approx. 2.5 V at 20 mA
Overload	100 mA, 30 V

Output data

Output	0(4) ... 20 mA/max. 27.5 V (corresponds to 1375 ohms load)
Residual ripple	< 5 mV _{rms}

Transmission behavior

Transmission error	< 0.1 % full scale
Load error	< 0.02 % meas. val./100 ohms
Response time (T_{90})	Approx. 5 ms at 500 ohm load
Temperature coefficient ¹⁾	< 0.002 %/K of meas. val. per 100 ohms load (reference temperature 23 °C)

1) Average TC in specified operating temperature range -10 ... +70 °C

Loop-Powered Isolators for Standard Signals

Isolation Amplifiers
Transmitters

Indicators

Process Analytics

Portable Meters

Laboratory Meters

Sensors

Fittings

Knick 

Specifications (continued)

Isolation

Test voltage	1.5 kV AC input against output of the same channel 2.3 kV AC channels against each other
--------------	---

Standards and approvals

EMC ²⁾	89/336/EEC directive, EN 61326
Approvals	UL: File No. E 220033, Standards: UL 508 and CAN/CSA 22.2 no. 14

Data for Option 506

Test voltage	4 kV AC input against output of the same channel 2.3 kV AC channels against each other
Protection against electric shock	Safe Isolation according to EN 61140 by reinforced insulation in accordance with EN 61010-1. Working voltages up to 300 V AC/DC across all terminals with overvoltage category II and pollution degree 2. For applications with high working voltages, you should ensure there is sufficient spacing or isolation from neighboring devices and protection against electric shocks.

Other data

MTBF ³⁾	Approx. 1031 years/channel
Ambient temperature	Operation: -10 ... +70 °C Transport and storage: -40 ... +85 °C
Design	Modular housing, width 12.5 or 22.5 mm, with pluggable screw terminal See dimension drawings for further measurements
Ingress protection	IP 20
Mounting	Metal lock for mounting on 35 mm top hat rail according to EN 50022 See dimension drawings for conductor cross section
Weight	Approx. 100 g

²⁾ Applies to 4 ... 20 mA, slight deviations are possible while there is interference

³⁾ Mean Time Between Failures – MTBF – according to EN 61709 (SN 29500).

Conditions: stationary operation in well-kept rooms, average ambient temperature 40 °C, no ventilation, continuous operation

Modular Housings

IsoTrans® A 47

Transfer Function

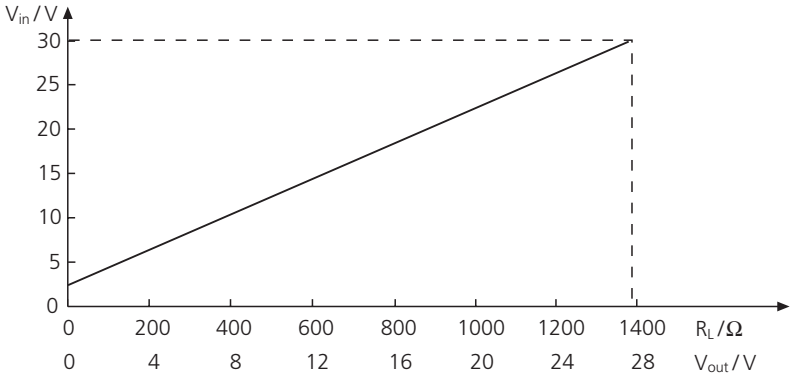

Block Diagram

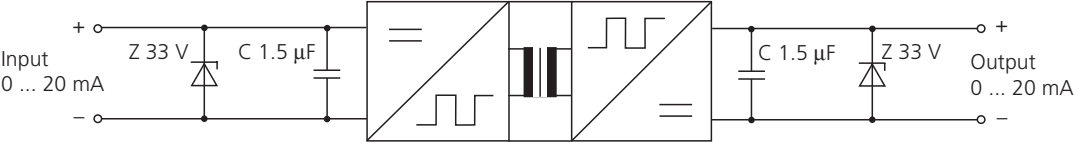

Loop-Powered Isolators for Standard Signals



■ Dimension Drawings and Terminal Assignments

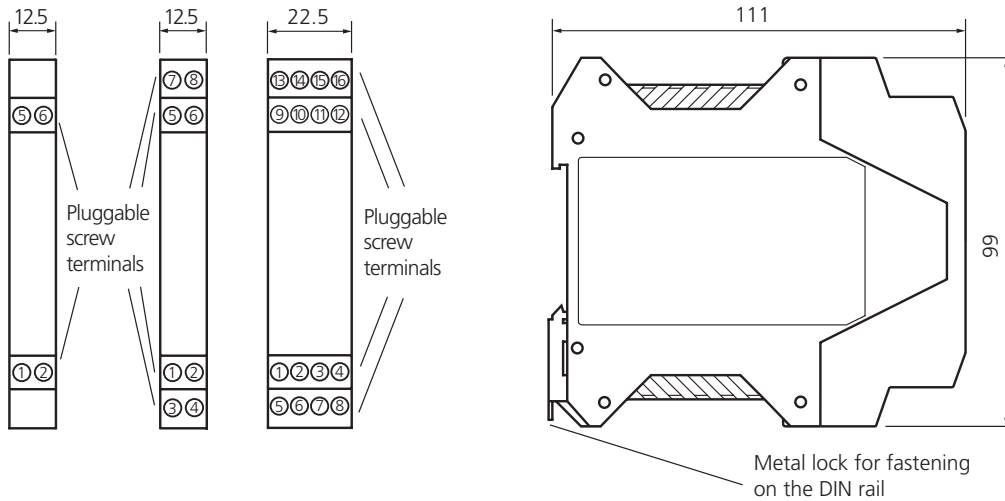

Conductor cross-section max. 2.5 mm²

Multi-wire connection max. 1 mm²
(two wires with same cross-section)

1- and 2-channel model

1	Input +	Channel 1
2	Input -	Channel 1
3	Input +	Channel 2
4	Input -	Channel 2
5	Output +	Channel 1
6	Output -	Channel 1
7	Output +	Channel 2
8	Output -	Channel 2

4-channel model

1	Input +	Channel 1	9	Output +	Channel 1
2	Input -	Channel 1	10	Output -	Channel 1
3	Input +	Channel 2	11	Output +	Channel 2
4	Input -	Channel 2	12	Output -	Channel 2
5	Input +	Channel 3	13	Output +	Channel 3
6	Input -	Channel 3	14	Output -	Channel 3
7	Input +	Channel 4	15	Output +	Channel 4
8	Input -	Channel 4	16	Output -	Channel 4

All dimensions in mm!

Modular Housings

Knick >

IsoTrans® B 48



**Unbelievably simple isolation!
20 mA transmission with electrical isolation.**

The Task

Preventing measuring errors or even destruction of the system normally requires floating connection of the sensors and actuators to the sensitive MSR electronics.

The Problem

was solved up to now with additional devices for electrical isolation after the routing and distributor level.

The Solution

comes in form of the 6-mm wide IsoTrans® B 48 isolating terminal. It fulfills all tasks set for modern terminals and safely and reliably isolates 0(4) ... 20 mA signals using loop power without distorting the measurement signal.

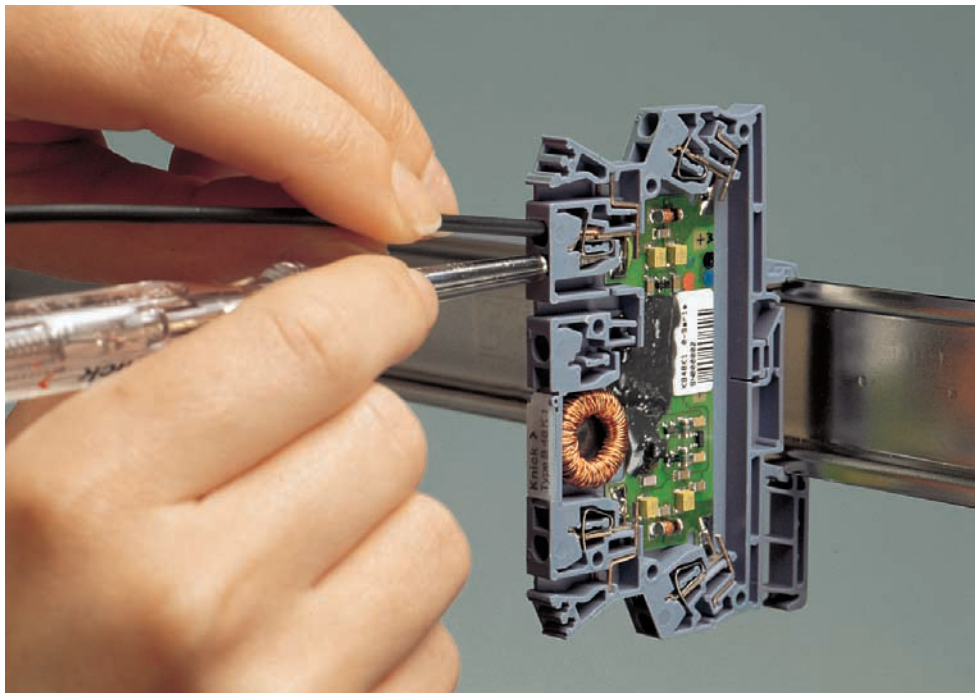

The Connections

use Z-springs and allow simple, fast, and safe connection of the wires.

specialty developed flat-core transformer have led to this extremely narrow housing with a width of just 6 mm. That are up to 166 isolating terminals per meter of mounting rail.

The Technology

The constantly improved circuit concept of our isolators that have been tried and tested over decades and draw their power as a voltage drop from the measurement signal and the use of a

Loop-Powered Isolators for Standard Signals

Isolation Amplifiers
Transmitters

Indicators

Process Analytics

Portable Meters

Laboratory Meters

Sensors

Fittings



Knick >

■ The Facts

Substantial cost- and space-savings

due to the omission of a whole installation stage

Minimum wiring effort

due to loop-powered electrical isolation and the combination of terminal and isolator in one device

Fast, simple, and safe wiring using Z-springs

High level of safety thanks to proven circuit technology

Galvanic isolation

Protection against incorrect measurements or damage to the equipment due to parasitic voltages

Extremely compact design

at just 6 mm in width the modular housing allows up to 166 channels per meter

Easy to use and to maintain

Simple and fast installation due to innovative Z-springs

No power supply required

Cost saving due to lower wiring effort, no mains influences

High accuracy

No distortion of measurement signal

5-year warranty

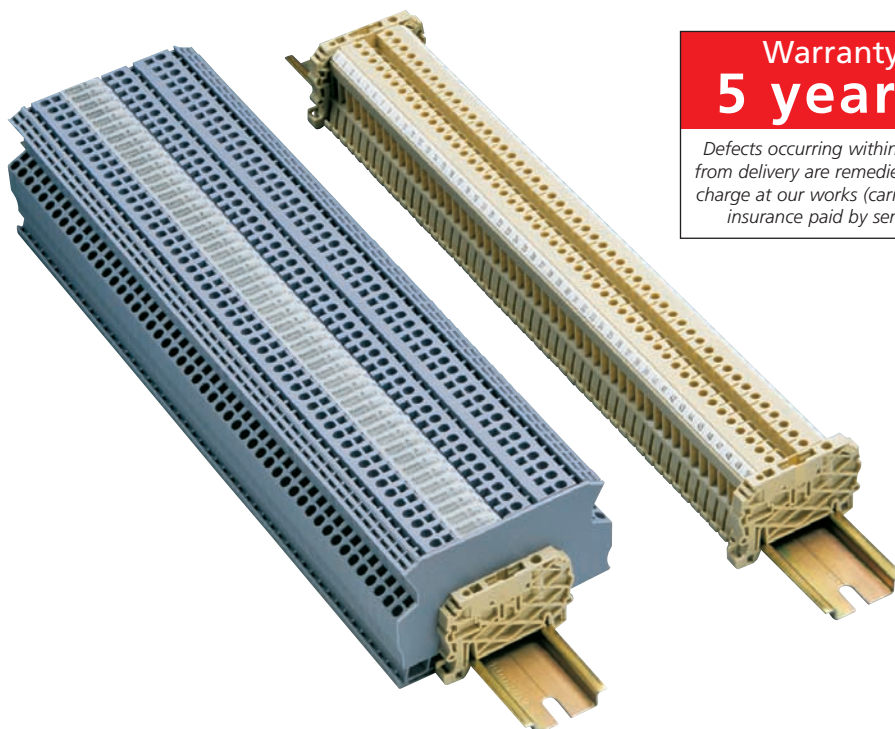

Warranty
5 years!

Defects occurring within 5 years from delivery are remedied free of charge at our works (carriage and insurance paid by sender).

Modular Housings

IsoTrans® B 48

■ Product Line

Devices	Input	Output	Order No.
IsoTrans® B 48	0 ... 20 mA, 4 ... 20 mA	0 ... 20 mA, 4 ... 20 mA	B 48 K1

Power supply

None, supply from input signal

Accessories

End plate	Shock-hazard protection for the last isolating terminal in the row, required 1x per application!	ZU 0286
-----------	--	---------

■ Specifications

Input data

Input	0 ... 20 mA (linear transmission up to 22 mA)
Operating current	< 100 µA
Voltage drop	Approx. 2.7 V at 20 mA
Overload	50 mA, 15 V

Output data

Output	0 ... 20 mA, ≤ 500 ohms
Residual ripple	< 10 mV _{rms}

Transmission behavior

Transmission error	< 0.1 % full scale
Load error	< 0.05 % meas. val./100 ohms
Response time (T ₉₀)	Approx. 5 ms at 500 ohm load
Temperature coefficient ¹⁾	< 0.005 %/K of meas. val. per 100 ohm load (reference temperature 23 °C)

Isolation

Test voltage	510 V AC
Working voltage	100 V with overvoltage category II and pollution degree 2 according to EN 61010-1

1) Average TC in specified operating temperature range -25 ... +60 °C

Loop-Powered Isolators for Standard Signals

Isolation Amplifiers
Transmitters

Indicators

Process Analytics

Portable Meters

Laboratory Meters

Sensors

Fittings

Knick 

Specifications (continued)

Standards and approvals

EMC ²⁾	89/336/EEC directive, EN 61326
-------------------	--------------------------------

Other data

Ambient temperature	Operation: -25 ... +60 °C also when mounted in row Transport and storage: -40 ... +85 °C
---------------------	---

Design	Terminal housing, 6 mm width, terminal using Z-spring technology See dimension drawings for further measurements
--------	---

Ingress protection	IP 20 in row or with end plate
--------------------	--------------------------------

Mounting	For 35 mm top hat rail according to EN 50022, see dimension drawings for conductor cross section
----------	---

Weight	12 g
--------	------

²⁾ Applies to 4 ... 20 mA, slight deviations are possible while there is interference

■ Input Voltage

depending on the load at $I_{out} = 20$ mA

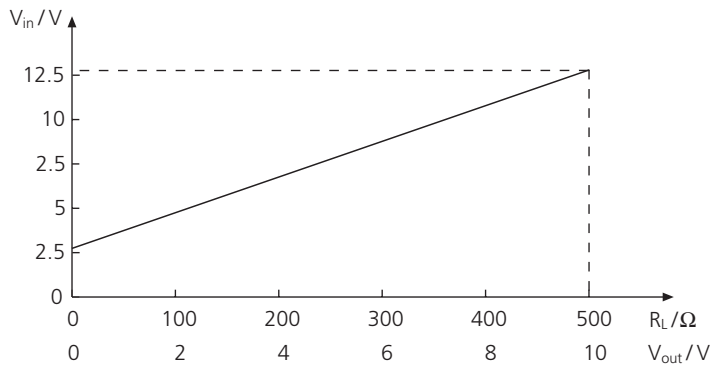

Modular Housings

IsoTrans® B 48

■ Block Diagram

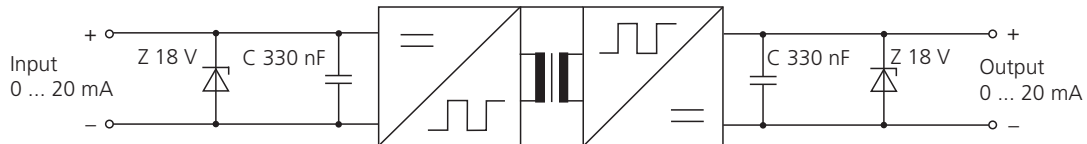

■ Dimension Drawings and Terminal Assignments

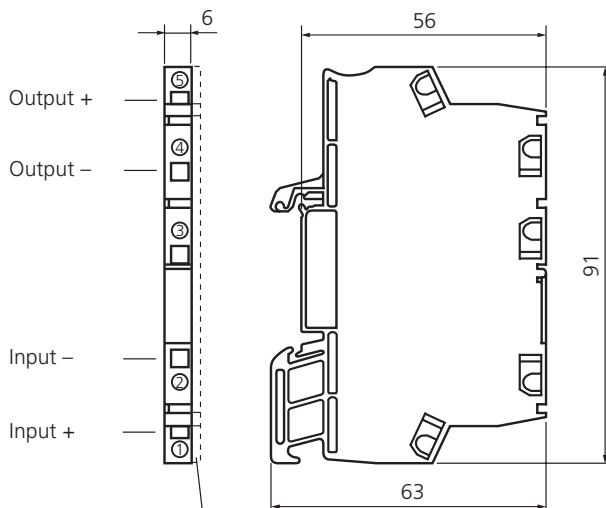

ZU 0286 end plate, 1.5 mm wide, only required for last device in row as shock-hazard protection

Conductor cross-sections:

Single-wire	0.5 ... 2.5 mm ²
Fine-wire	0.5 ... 2.5 mm ²
With ferrule	0.5 ... 1.5 mm ²

All dimensions in mm!

Isolation Amplifiers for Standard Signals

Isolation Amplifiers
Transmitters

Indicators

Process Analytics

Portable Meters

Laboratory Meters

Sensors

Fittings

Knick 

Modular Housings

Knick >

IsoTrans® A 20400



The first reactionless passive isolator comprising the Bürdenstop® function to provide safe isolation of 0(4) ... 20 mA standard signals.

The Task

Measurement signals between sensor and controller should be isolated galvanically to ensure reliable and safe operation of the installation. Here, loop-powered standard signal isolators are a low-cost solution. There is no expenditure for power supply units and their wiring.

The Problems

are often, particularly in large plants, the lack of space for mounting the isolators and the increasing operating temperatures in distributors and switch cabinets.

The Solution

comes in the form of the Knick Advanced Series IsoTrans® A 20400 loop-powered isolators. An extremely high component density of up to 320 channels per meter top-hat rail and excellent technical properties, such as their safe isolation, make the isolators unbeatable – as does their price-performance ratio!

The Housing

The ultra-slim 6 mm wide modular housing for one or two channels allows simple and fast assembly.

The Function Principle

The IsoTrans® A 20400 obtains its power directly from the measurement signal as a voltage drop without distorting it.

There are no costs for a power supply and wiring.

The IsoTrans® A 20400 more or less has no self-heating that would cause the electronic components to age faster.

Together with a patented switching technique, this means maximum reliability. Due to this extraordinary long service life: 5 years warranty!

The Technology

A transmission error of just 0.1%, excellent square-wave response and very low residual ripple guarantee perfect signal transmission. The low voltage drop of approx. 1.7 V only loads the signal slightly.

The high test voltage up to 2.5 kV and Safe Isolation up to 300 V according to EN 61140 protect the operating personnel against, for example, the mains voltage.

Interference-Free Functionality

Now Knick has considerably expanded the application possibilities of passive isolators by implementing a Bürdenstop® (load stop) function. Here, the current supplied at the primary side is maintained independently from the output load. Thus, for the first time any excessive load increase at the output, such as caused by line breakage or inconstant loads including complex impedances, can be compensated for.

Warranty
5 years!

Defects occurring within 5 years from delivery are remedied free of charge at our works (carriage and insurance paid by sender).

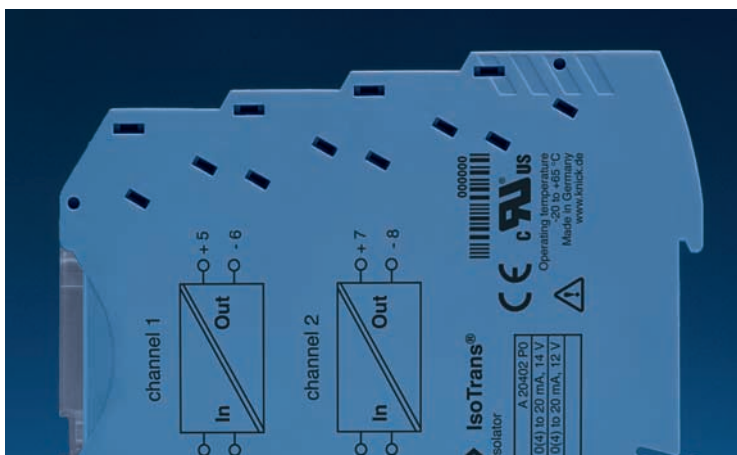

Isolation Amplifiers for Standard Signals

Isolation Amplifiers
Transmitters

Indicators

Process Analytics

Portable Meters

Laboratory Meters

Sensors

Fittings



Knick >

■ The Facts

Extremely compact design

up to 320 channels per meter

1 and 2-channel versions

cheap and flexible for a wide range of applications

Galvanic isolation

between input and output

Protection against incorrect measurements or damage to the equipment due to parasitic voltages

Safe Isolation up to 300 V AC/DC according to EN 61140

to protect personnel and equipment

Bürdenstop® prevents undesired feedback

e.g. in the case of an open output circuit

No power supply required

Cost savings due to lower wiring requirement, no mains influences, no unnecessary heating and therefore maximum service life of components

High accuracy

No distortion of measurement signal

Maximum reliability

No repair and failure costs

International use

UL/CSA approvals

5-year warranty



Modular Housings

IsoTrans® A 20400

■ Product Line

Devices	Input	Order No.
IsoTrans® A 20400	1-channel, modular housing P0 (6 mm wide)	A 20401 P0
	2-channel, modular housing P0 (6 mm wide)	A 20402 P0
	1-channel, modular housing P0 (6 mm wide), with Bürdenstop®	A 20411 P0
	2-channel, modular housing P0 (6 mm wide), with Bürdenstop®	A 20412 P0

Power supply

None, supply from input signal

■ Specifications

Input data	A 20401 and A 20402 (without Bürdenstop®)	A 20411 and A 20412 (with Bürdenstop®)
Input	0(4) ... 20 mA/max. 18 V	0(4) ... 20 mA/max. 3 V
Operating current	Approx. 150 µA	Approx. 150 µA
Voltage drop	Approx. 1.7 V at 20 mA	Approx. 1.5 V at 20 mA
Overload	40 mA, 18 V	50 mA, 3 V
Output data		
Output	0(4) ... 20 mA/max. 12 V (600 ohm load at 20 mA)	0(4) ... 20 mA/max. 1.2 V (60 ohm load at 20 mA)
Residual ripple	< 10 mV _{rms}	< 10 mV _{rms}
Transmission behavior		
Transmission error	< 0.1 % full scale	< 0.1 % full scale
Load error	< 0.05 % meas. val./100 ohms	Negligible
Response time (T ₉₉)	Approx. 5 ms at 500 ohm load	Approx. 5 ms at 60 ohm load
Temperature coefficient ¹⁾	< 0.002 %/K of meas. val. per 100 ohm load (reference temperature 23 °C)	< 0.002 %/K of meas. val. (reference temperature 23 °C)

1) Average TC in specified operating temperature range -20 ... +65 °C

Isolation Amplifiers for Standard Signals

Isolation Amplifiers
Transmitters

Indicators

Process Analytics

Portable Meters

Laboratory Meters

Sensors

Fittings

Knick 

Specifications (continued)

Isolation

Test voltage	2.5 kV AC
Working voltage (basic insulation)	Up to 600 V AC/DC with overvoltage category II and pollution degree 2 across input and output of the same channel and channels against each other.
Protection against electric shock	Safe Isolation according to EN 61140 by reinforced insulation in accordance with EN 61010-1. Working voltages up to 300 V AC/DC across input and output of the same channel and across different channels with overvoltage category II and pollution degree 2 . For applications with high working voltages, you should ensure there is sufficient spacing or isolation from neighboring devices and protection against electric shocks.

Standards and approvals

EMC ²⁾	Product standard: EN 61326 Emitted interference: Class B Immunity to interference: Industry
Approvals	cUL: Standards: UL 508 and CAN/CSA 22.2 no. 14-95 GL: No. 32650-06 HH

Other data

MTBF ³⁾	Approx. 1031 years/channel
Chopper frequency	Approx. 100 kHz
Ambient temperature	Operation: -20 ... +65 °C Transport and storage: -25 ... +85 °C
Design	Modular housing with screw terminals, 6.2 mm wide, see dimension drawings for further measurements
Ingress protection	IP 20
Mounting	For 35 mm top hat rail to EN 50022
Weight	Approx. 50 g

2) Applies to 4 ... 20 mA, slight deviations are possible while there is interference

4) Mean Time Between Failures – MTBF – according to EN 61709 (SN 29500).

Conditions: stationary operation in well-kept rooms, average ambient temperature 40 °C, no ventilation, continuous operation

Modular Housings

IsoTrans® A 20400

■ Transfer Function with Bürdenstop® (load stop)

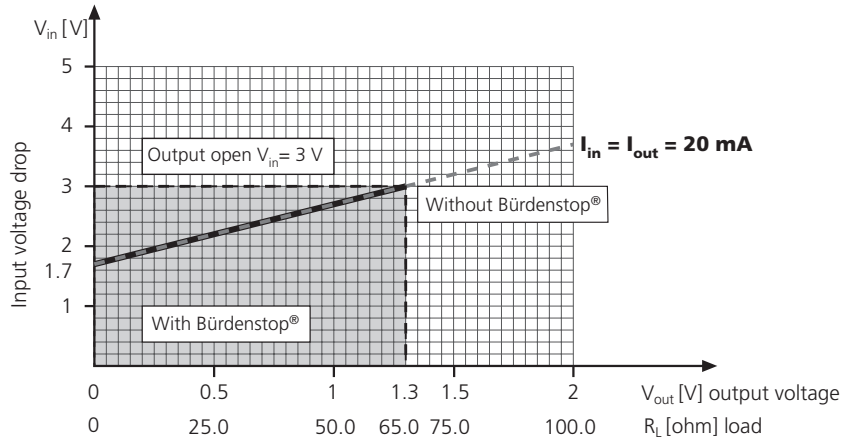

■ Block Diagram

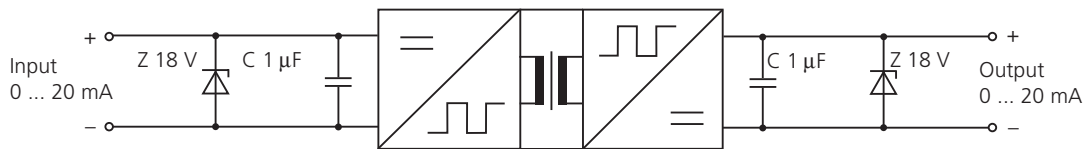

■ Application Example

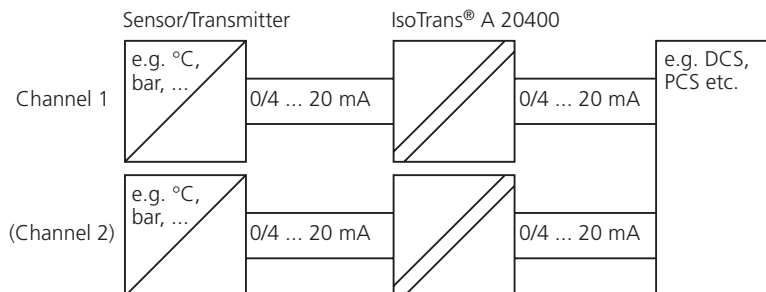

Isolation Amplifiers for Standard Signals

Isolation Amplifiers
Transmitters

Indicators

Process Analytics

Portable Meters

Laboratory Meters

Sensors

Fittings

Knick 

■ Dimension Drawings and Terminal Assignments

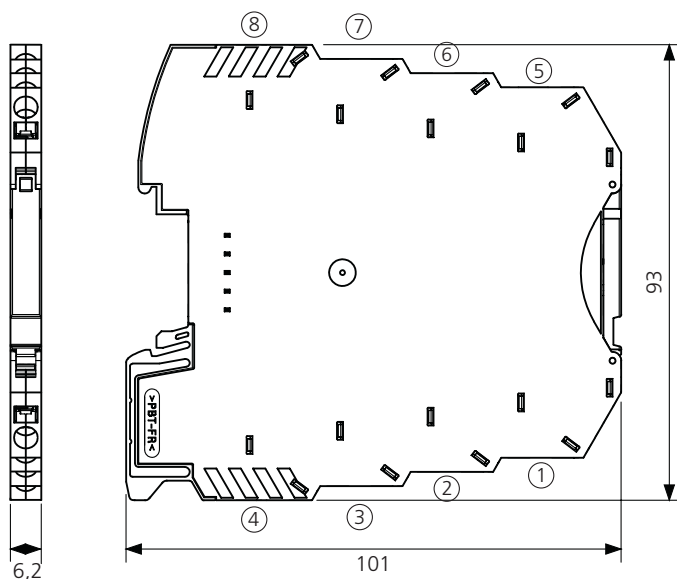

- ① Input 1, +
- ② Input 1, -
- ③ Input 2, +
- ④ Input 2, -
- ⑤ Output 1, +
- ⑥ Output 1, -
- ⑦ Output 2, +
- ⑧ Output 2, -

Conductor cross-sections
 - Single-wire: 0.2 ... 2.5 mm²
 - Fine-wire: 0.2 ... 2.5 mm²
 - 24-14 AWG

All dimensions in mm!