

It's TRUE!

True RMS measurement with the new AC/DC high-voltage transmitters of the VariTrans® P 40000 TRMS series

Isolation Amplifiers
Transmitters

Indicators

Process Analytics

Portable Meters

Laboratory Meters

Sensors

Fittings

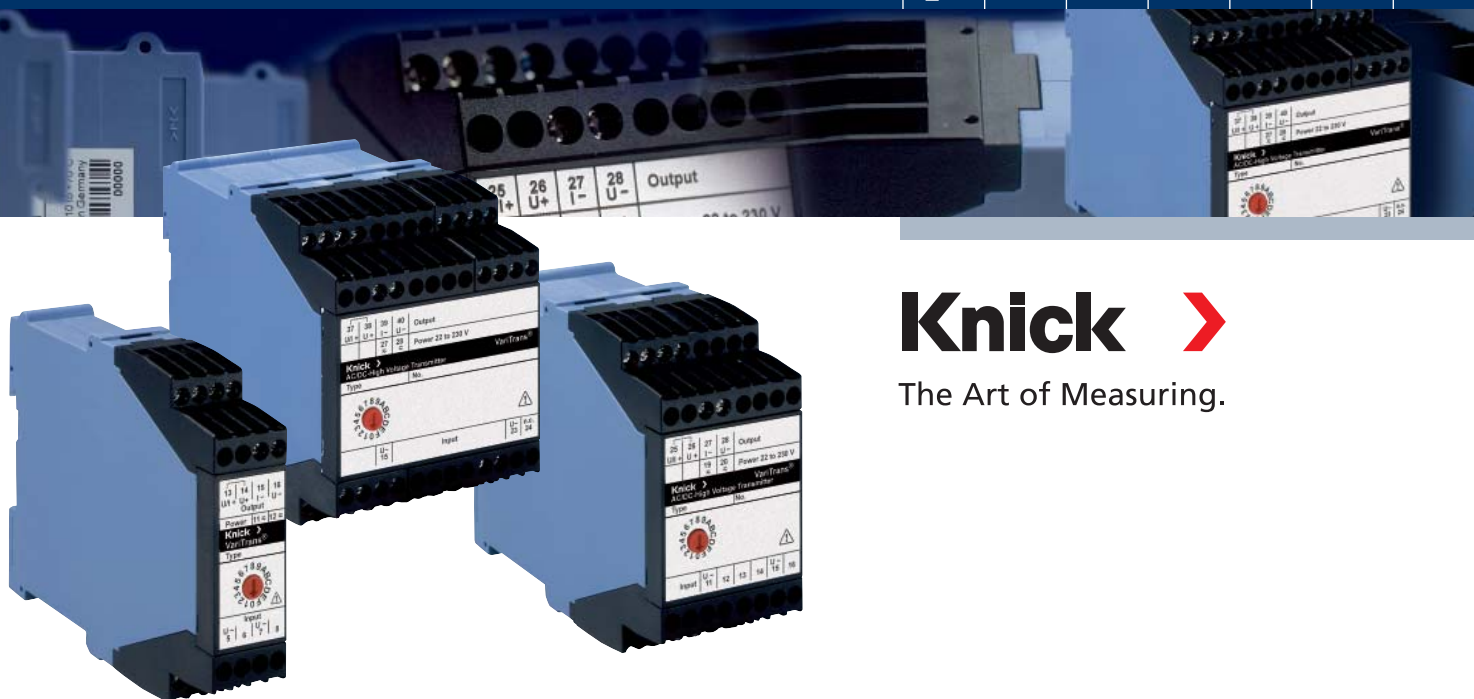

Knick 

The Art of Measuring.

A Class of Its Own. AC/DC High-Voltage Transmitters With True RMS



The Art of Measuring.



VariTrans® P 40000 TRMS

The AC/DC high-voltage transmitters are the optimal supplement to the P 40000 series. Knick has defined a completely new class of AC/DC transmitters by transferring the unique combination of product properties of this series to the measurement of AC signals.

No other device available on the market comes close to this astonishing combination of performance features:

- AC voltage measurement up to 3600 V~
- AC current measurement up to 5 A~
- 16 calibrated input/output signal combinations switchable on the front panel
- Working voltages up to 3600 V AC/DC
- Test voltages up to 15 kV AC
- Integrated 20 to 253 V AC/DC broad-range power supply

■ The VariTrans® P 40000 TRMS AC/DC High-Voltage Transmitters

transform the RMS value of the alternating input voltage or current into a standardized direct current or direct voltage signal. The output signal is safely galvanically isolated from the input signal and the voltage supply.

■ RMS or Rather TRMS?

Simple AC/DC transmitters operate according to an averaging technique which uses the form factor for sinusoidal waveforms

(RMS value/arithmetic mean = 1.11) to transform RMS values. Here, the RMS (root-mean-square) value is the effective value of a sinusoidal AC signal.

A measurement technique using the correction factor 1.11 is only suitable for pure sine waves. Distorted sine waves can produce considerable deviations (see figure). The VariTrans® P 40000 TRMS AC/DC high-voltage transmitters, however, measure the true RMS value (TRMS) of any kind of complex AC signals. Thus, even strongly distorted sinusoidal or pulse-shaped signals are evaluated correctly (see figure). Disturbing DC components are not considered.

Signal shape	Form factor	Crest factor	RMS transmitter with correction factor 1.11	VariTrans® P 40000 TRMS
	$\frac{\pi}{2\sqrt{2}} = 1.11$	$\sqrt{2}$	Exact	Exact
	$\frac{\pi}{\sqrt{3}} = 1.155$	$\sqrt{3}$	Meas. error $\geq 4\%$	Exact
	$\frac{\pi}{2} = 1.57$	2	Meas. error $\geq 30\%$	Exact

RMS value: The RMS (or root-mean-square) value of an AC or AC/DC signal corresponds to a pure DC signal that converts the same amount of energy. This means that it produces the same temperature rise in an ohmic load as a direct current of the same value; an incandescent lamp, for example, would light with the same intensity. When measuring non-sinusoidal signals, simple AC/DC converters without TRMS take no account of the exact correlation between the energy supplied to an ohmic load and the measured non-sinusoidal current and voltage values. Because of the square-law relationship between power and current or voltage, this may produce large errors. Knowing the true RMS values is therefore a decisive contribution to increased process safety.



■ Crest Factor and Signal Frequency

The crest factor provides a simple means to determine the waveform of a signal. It is the ratio of the peak value to the RMS value of an electrical quantity. The crest factor of a sinusoidal waveform is $C = \sqrt{2} = 1.414$. The measuring range of an AC/DC transmitter is limited by the crest factor and/or the signal frequency.

The crest factor of the VariTrans® P 40000 TRMS series ranges from 1 to 5. All power-engineering frequencies, such as 16.7 Hz (railway systems), 400 Hz (electrical systems of aircrafts and ships), and in particular 50 Hz and 60 Hz (mains frequency) are processed. This makes the VariTrans® P 40000 TRMS AC/DC high-voltage transmitters suitable for the measurement of even strongly distorted signals. With higher crest factors and/or other signal frequencies, the measurement accuracy will be reduced.



■ TransShield® Technology

Also in this series, Knick relies on the TransShield® technology which compared to conventional designs enables very compact high-voltage transformers with low leakage. Thanks to the resulting space advantage, the P 41000 TRMS shunt isolators could be installed in an only 22.5 mm wide modular housing. Another substantial advantage of this technology: High transient overvoltages (common-mode interference) are reliably isolated and cause hardly any measurement errors at the output.

■ Calibrated Range Selection

A highly functional and unique feature of AC/DC high-voltage

transmitters is the calibrated range selection: Input/output signal combinations can easily be selected using a rotary coding switch on the front panel. Easy scalability of the range selection supports customized solutions; optimally adapted to the respective application, up to 16 tailor-made signal combinations can be implemented in one device.

■ Integrated Broad-Range Power Supply

Maximum flexibility and direct added value for the user is also provided by the integrated VariPower® broad-range power supply (20 ... 253 V AC/DC). This ensures trouble-free operation with alternating or direct voltages everywhere in the world and provides for maximum safety even in unstable power supply networks. Installation is also easy and safe: Incorrect assignment of the mains voltage is practically excluded; expensive downtimes and repairs during commissioning are avoided.

■ Maximum Safety

Special vacuum encapsulation protects the circuitry against environmental influences and ensures the high disruptive strength required for working voltages up to 3600 V AC/DC.



A Class of Its Own. AC/DC High-Voltage Transmitters With True RMS

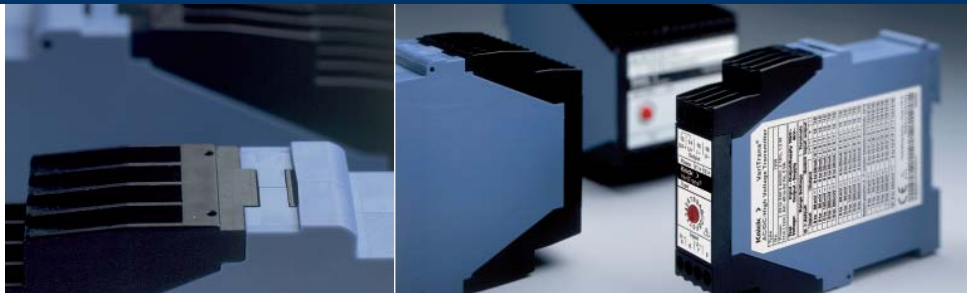

At the same time, not only the safety regulations stipulated in EN 61010-1 but also the regulations of the EN 50124-1 standard (insulation coordination for railway applications) are observed. Thus the isolators are excellently equipped for galvanically isolated measurements of railway transportation systems. To guarantee the specified isolation capabilities, the devices are subjected to routine testing with 15 kV AC (fixed-range models) or 10 kV AC (switchable models) on a 100 % basis. The vacuum encapsulation technology employed by Knick provides maximum long-term protection against aggressive environmental influences, shock, and vibrations.

■ Superior Functionality

Also in the new VariTrans® P 40000 TRMS series, the circuit design and device construction ensure excellent transmission quality which is reflected in the zero stability, linearity, long-term

stability, frequency response, and immunity to interference. The new AC/DC high-voltage transmitters from Knick accept a wide range of input signals: from a millivolt range – for example for measuring large currents via shunt resistors – to high AC voltages in the kilovolt range. AC currents up to 5 A can be measured directly. Analog standard signals are available at the output of the AC/DC high-voltage transmitters. The user can select any combination of input and output signals and thus take into account the individual operating conditions.

■ Versatile Applications

The VariTrans® P 40000 TRMS transmitters are ideal for current and voltage measurements in energy networks. Further applications are the monitoring and control of electric drive systems that can be operated at medium or high voltages.

Their sturdy design also makes them suitable for use in rail vehicles. Here, their main tasks include voltage/current monitoring in traction and auxiliary converters.

The high performance and flexibility previously unknown for this device class supports the user in the development of the most diverse product or system solutions.

■ Optimized Product Lines

Three product lines in 22.5 to 67.5 mm wide housings are offered for different measuring ranges and standard requirements – either as variants with fixed settings or as models with calibrated range selection. The working voltage for fixed-range models is 2200/3600 V AC/DC (test voltage 10/15 kV AC) and 2200 V AC/DC (test voltage 10 kV AC) for switchable models. Impressed DC signals 4 ... 20 mA, 0 ... 20 mA, or 0 ... 10 V are available at the output. Customer-specific devices can be equipped with up to 16 freely selectable signal combinations, and even special variants with bipolar output signals and/or high zero offset present no problem.

Subject to change without notice



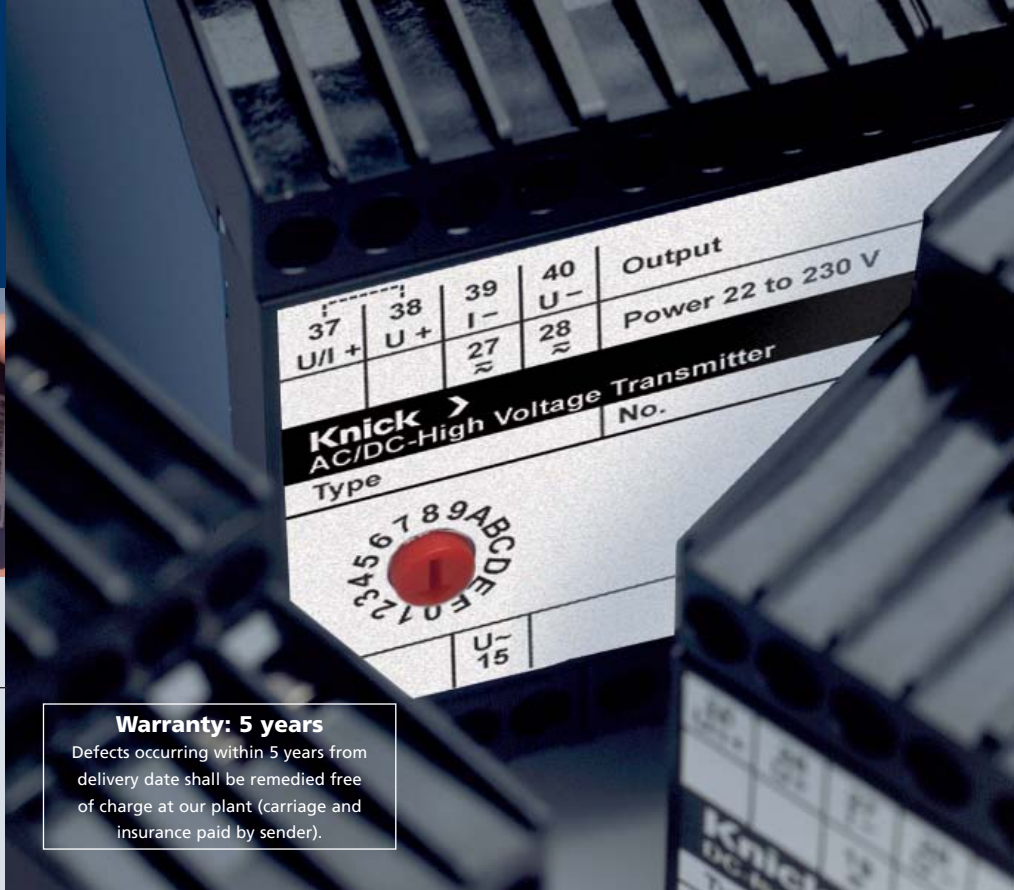

The Facts:

- Universal usability:
AC input 60 mV~ up to 3600 V~
as well as 100 mA~ up to 5 A~

- DC output 0(4) ... 20 mA, 0 ... 10 V

- TransShield® technology enables
extremely compact modular housings

- Working voltages up to 3600 V AC/DC

- Protection against electric shock
through Safe Isolation up to
1800 V AC/DC

- Test voltages up to 15 kV AC

- Excellent transmission properties:
– Gain error
 Crest factor ≤ 3 $< 0.5\%$
– Gain error
 Crest factor 3 ... 5 $< 1\%$
– Response T90 $< \text{appr. } 100 \text{ ms}$

- Virtually no influence from common-
mode voltages:
CMRR approx. 150 dB

- High immunity to transient noise:
T-CMR approx. 105 dB

- Tremendous flexibility provided by
– calibrated switching of up to
 16 input/output ranges
– up to 16 customer-specific ranges
– VariPower® 20 V to 253 V AC/DC
 broad-range power supply

- Reliable function even with unstable
supply

- No destruction in the event of
erroneously incorrect mains voltage

- Switchable models reduce variety of
versions, thus saving storage costs

- Robust thanks to vacuum encapsulation

- Mechanically stable for operation on
ships, rail vehicles, and land crafts

- Warranty: 5 years

Warranty: 5 years
Defects occurring within 5 years from
delivery date shall be remedied free
of charge at our plant (carriage and
insurance paid by sender).

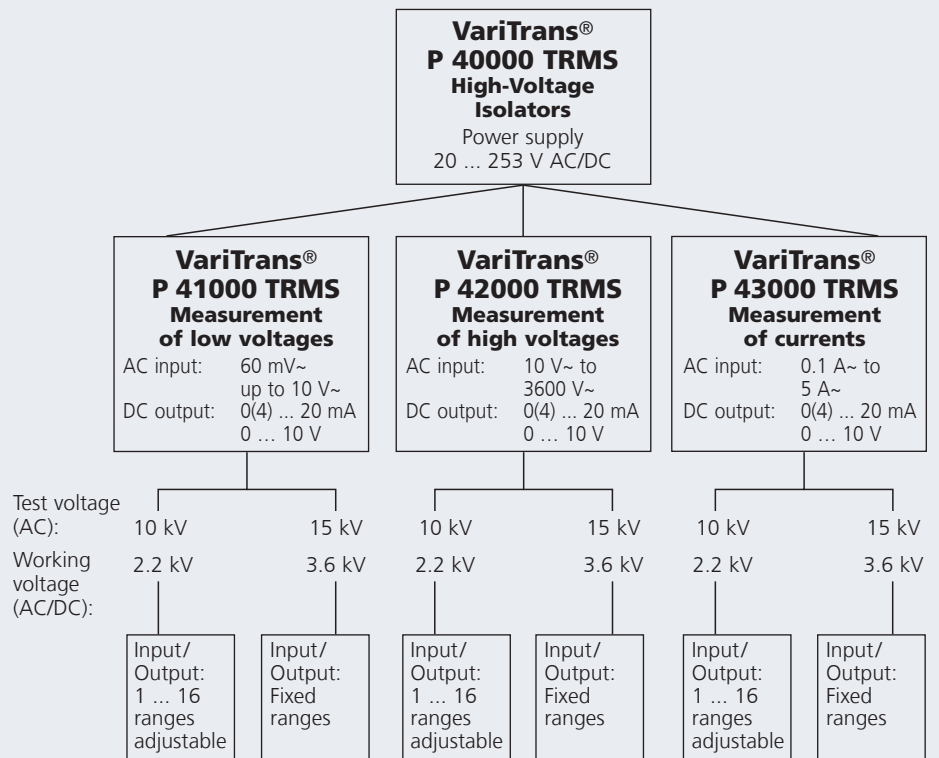



VariTrans® P 41000 TRMS AC/DC High-Voltage Transmitters With True RMS, AC Input 60 mV~ to 10 V~

Universal AC/DC high-voltage transmitter for sinusoidal and non-sinusoidal AC input signals in the range from 60 mV to 10 V. True RMS value as standard-signal output for further processing in controllers or data acquisition systems. Calibrated selection of input and output.

■ Product Line

Devices	AC input	Output TRMS value	Working voltage	Test voltage	Order no.
VariTrans® P 41000 TRMS Input and output switchable	60 mV ... 10 V AC 1 to 16 ranges to customer requirement (low/high end of range ≤10)	0 ... 20 mA, 4 ... 20 mA, and/or 0 ... 10 V, 1 to 16 ranges to customer requirement	≤2.2 kV AC/DC	10 kV AC	P 41000 D1 TRMS-nnnn
VariTrans® P 41100 TRMS Input and output with fixed settings	60 mV ... 10 V AC to customer requirement	0 ... 20 mA, 4 ... 20 mA, or 0 ... 10 V to customer requirement	≤3.6 kV AC/DC	15 kV AC	P 41100 D1 TRMS-nnnn

“Specific Test Report” included in shipment

Power supply

20 ... 253 V AC/DC

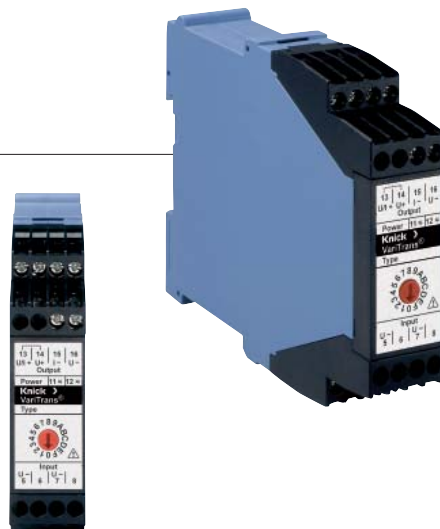

■ Specifications

Input Data

Input	P 41000 D1 TRMS-nnnn	60 mV ... 10 V AC; 1 to 16 customer-specific ranges, calibrated selection
	P 41100 D1 TRMS-nnnn	60 mV ... 10 V AC; range fixed to customer requirement
Rated frequency	50/60 Hz	
Frequency range	40 ... 1000 Hz (frequency \leq 40 Hz on request)	
Input resistance	approx. 100 kohms	
Input capacitance	Approx. 1 nF	
Overload	Range \leq 0.5 V	limited by suppressor diode 6.8 V, permitted continuous current = 50 mA
	Range $>$ 0.5 V ... 10 V	limited by suppressor diode 68 V, permitted continuous current = 5 mA

Output Data

Output	P 41000 D1 TRMS-nnnn	0 ... 20 mA, 4 ... 20 mA and/or 0 ... 10 V to customer requirement, switchable
	P 41100 D1 TRMS-nnnn	0 ... 20 mA, 4 ... 20 mA or 0 ... 10 V to customer requirement, fixed settings
Displacement	Up to 100 % as default	
Load	With output current	\leq 12 V (600 ohms at 20 mA)
	With output voltage	\leq 10 mA (1000 ohms at 10 V)
Residual ripple	$<$ 10 mVrms	

Transmission Behavior

Gain error	$<$ 0.3 % full scale Gain error for sinusoidal input signals (crest factor $\sqrt{2}$) in the frequency range 45 ... 65 Hz	
Response T90	$<$ 150 msec rising $<$ 300 msec falling	
Influential factors (additional error)	Frequency 40 ... 1000 Hz	$<$ 1 % meas. val. (typ. 0.5 %)
	Crest factor 1 ... 3 (non-sinusoidal signals)	$<$ 0.5 % meas. val.
	Crest factor $>$ 3 ... 5	$<$ 1 % meas. val.

VariTrans® P 41000 D1 TRMS

Specifications (continued)

Common mode rejection ratio	Input ranges ≤ 0.5 V	CMRR	Appr. 150 dB (DC/AC: 50 Hz)
	Other input ranges	T-CMRR CMRR	Appr. 105 dB (1000 V, tr = 1 μ s) DC: approx. 150 dB AC 50 HZ, approx. 120 dB
CMRR: Common-Mode Rejection Ratio = Differential voltage gain : Common-mode voltage gain T-CMRR: Transient Common-Mode Rejection = Differential DC gain : Common-mode transient peak value gain			
Temperature influence	<50 ppm/K full scale Reference temperature for TC specifications = 23 °C, average TC is specified		
Power Supply			
Power supply	20 ... 253 V AC/DC, AC 48 ... 62 Hz, approx. 2 VA; DC approx. 1.2 W		
Isolation			
Galvanic isolation	3-port isolation between input, output, and power supply		
Test voltage	Calibrated switching	10 kV AC input against output and power supply	
	Fixed settings (Model P 41100 D1 TRMS-nnnn)	15 kV AC input against output and power supply	
	All models	4 kV AC output against power supply	
Working voltage (basic insulation) to EN 61010-1	Calibrated switching	Up to 2200 V AC/DC across input, output, and power supply with overvoltage category III and pollution degree 2 (fast transients: 13.5 kV)	
	Fixed settings (Model P 41100 D1 TRMS-nnnn)	Up to 3600 V AC/DC across input, output, and power supply with overvoltage category III and pollution degree 2 (fast transients: 20 kV)	
Rated isolation voltage to EN 50124-1	Calibrated switching	Up to 2200 V AC/DC across input, output, and power supply with overvoltage category III and pollution degree 2	
	Fixed settings (Model P 41100 D1 TRMS-nnnn)	Up to 3600 V AC/DC across input, output, and power supply with overvoltage category III and pollution degree 2	



Specifications (continued)

Protection against electric shock	Calibrated switching	<p>Safe Isolation to EN 61140 by reinforced insulation according to EN 61010-1.</p> <p>Working voltages with overvoltage category III and pollution degree 2:</p> <ul style="list-style-type: none"> - Up to 1100 V AC/DC across input, output, and power supply - Up to 300 V AC/DC across output and power supply
	Fixed settings (Model P 41100 D1 TRMS-nnnn)	<p>Safe Isolation to EN 61140 by reinforced insulation according to EN 61010-1.</p> <p>Working voltages with overvoltage category III and pollution degree 2:</p> <ul style="list-style-type: none"> - Up to 1800 V AC/DC across input, output, and power supply - Up to 300 V AC/DC across output and power supply <p>For applications with high working voltages, you should ensure there is sufficient spacing or isolation from neighboring devices and protection against electric shocks.</p>

Standards and Approvals

EMC	Product family standard	EN 61326
	Emitted interference	Class B
	Immunity to interference	Industry
	Slight deviations are possible while there is interference	

Other Data

Ambient temperature	Operation	-10 ... +70 °C
	Operation with restricted data (on request)	-40 ... +85 °C
	Transport and storage	-40 ... +85 °C
Design	Modular housing	Housing width D1: 22.5 mm
	With screw terminals	See dimension drawings for further measurements
Ingress protection	IP 40 enclosure, IP 20 terminals	
Fastening	With snap-on mounting for 35 mm top-hat rail according to EN 60715	
Weight	Approx. 180 g	

VariTrans® P 41000 D1 TRMS

■ Application Example

AC current measurement via shunt resistor

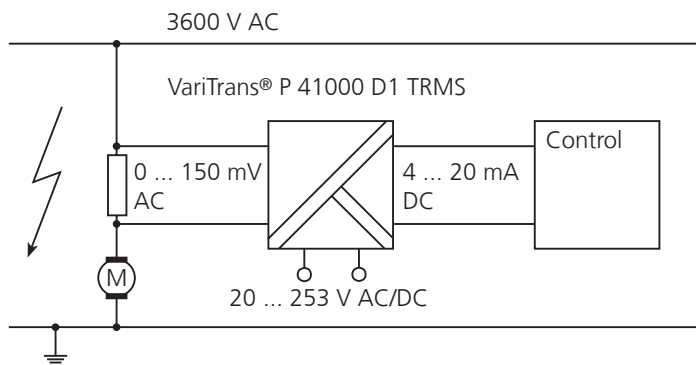

■ Block Diagram

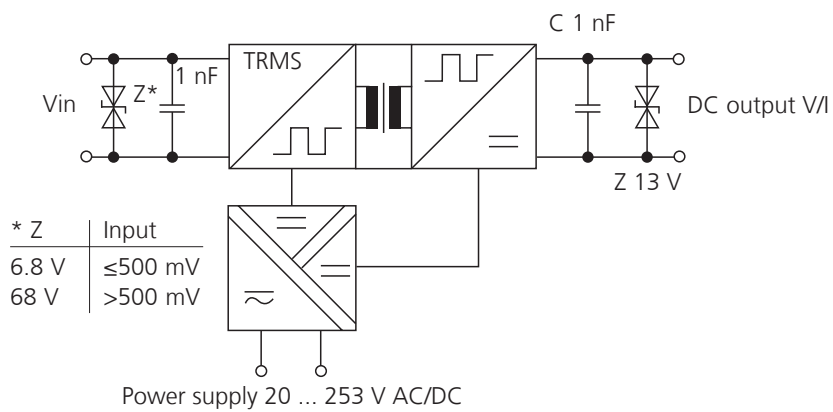

■ Dimension Drawings and Terminal Assignments

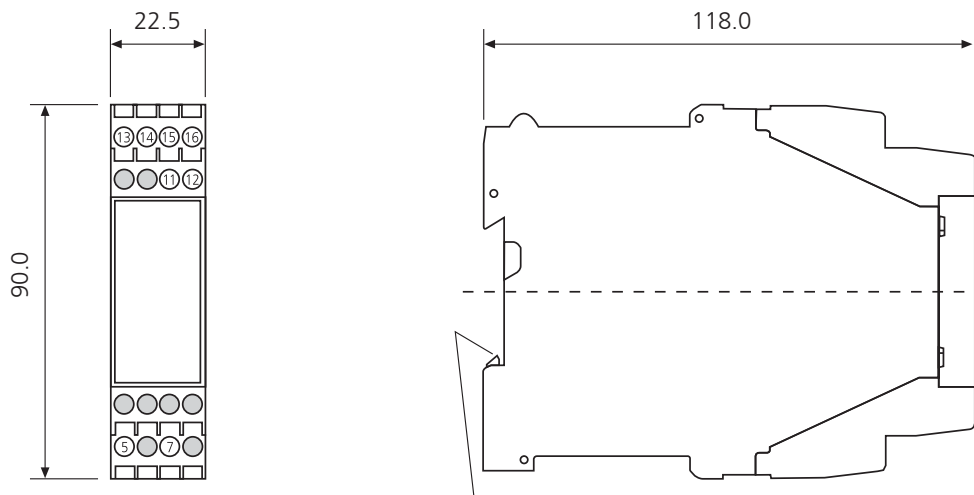

Snap-on mounting for 35 mm top hat rail EN 50 022

Please note: All dimensions in mm.

Terminal Assignments:

5	Input AC voltage 60 mV ... 10 V AC
7	Input 0
11	AC/DC power supply
12	AC/DC power supply
13	DC output current/voltage +
14	DC output voltage +
15	DC output voltage –
16	DC output voltage –

M 3.5 connecting screws with self-releasing terminal housing
conductor cross-section max. 1 x 4 mm²
solid or 1 x 2.5 mm² stranded with sleeve,
min. 1 x 0.5 mm² solid or stranded with sleeve

For switchable devices and voltage output,
place jumper across terminals 13 and 14



VariTrans® 42000 TRMS AC/DC High-Voltage Transmitters With True RMS AC Input 10 V~ to 3600 V~

Universal AC/DC high-voltage transmitter for sinusoidal and non-sinusoidal AC input signals in the range from 10 V to 3600 V. True RMS value as standard-signal output for further processing in controllers or data acquisition systems. Calibrated selection of input and output.

■ Product Line

Devices	AC input	Output TRMS value	Working voltage	Test voltage	Order no.
VariTrans® P 42000 TRMS Input and output switchable	10 V ... 1200 V AC 1 to 16 ranges to customer requirement (range spread limited)	0 ... 20 mA, 4 ... 20 mA, and/or 0 ... 10 V, 1 to 16 ranges to customer requirement	≤2.2 kV AC/DC	10 kV AC	P 42000 D2 TRMS-nnnn
	1200 V ... 2200 V AC 1 to 16 ranges to customer requirement (range spread limited)	0 ... 20 mA, 4 ... 20 mA, and/or 0 ... 10 V, 1 to 16 ranges to customer requirement	≤2.2 kV AC/DC	10 kV AC	P 42000 D3 TRMS-nnnn
VariTrans® P 42100 TRMS input and output with fixed settings	10 V ... 1200 V AC to customer requirement	0 ... 20 mA, 4 ... 20 mA, or 0 ... 10 V, to customer requirement	≤3.6 kV AC/DC	15 kV AC	P 42100 D2 TRMS-nnnn
	1200 V ... 3600 V AC to customer requirement	0 ... 20 mA, 4 ... 20 mA, or 0 ... 10 V, to customer requirement	≤3.6 kV AC/DC	15 kV AC	P 42100 D3 TRMS-nnnn

"Specific Test Report" included in shipment

Power supply

20 ... 253 V AC/DC

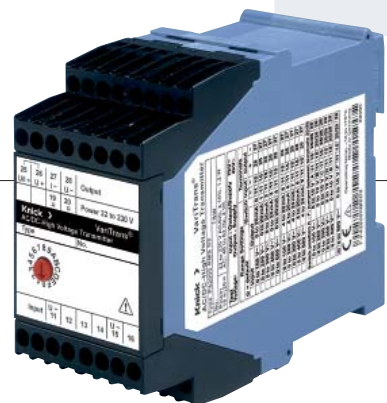

■ Specifications

Input Data

Input	P 42000 D2 TRMS-nnnn	10 V ... 1200 V AC; 1 to 16 customer-specific ranges, calibrated selection
	P 42000 D3 TRMS-nnnn	1200 V ... 2200 V AC; 1 to 16 customer-specific ranges, calibrated selection
	P 42100 D2 TRMS-nnnn	10 V ... 1200 V AC; range fixed to customer requirement
	P 42100 D3 TRMS-nnnn	1200 V ... 3600 V AC; range fixed to customer requirement
Rated frequency	50/60 Hz	
Frequency range	40 ... 1000 Hz (frequency \leq 40 Hz on request)	
Input resistance	Range 10 V ... 100 V AC	approx. 1 Mohm
	Range 100 V ... 500 V AC	approx. 3.6 Mohm
	Range 500 V ... 1200 V AC	approx. 7.2 Mohm
	Range 1200 V ... 3600 V AC	approx. 14 Mohm
Input capacitance	Approx. 1 nF	
Overload	D2: 20 % full scale (max. crest factor 8), max. crest voltage \leq 2000 V	
	D3: 20 % full scale or < 3900 V AC (max. crest factor 8), max. crest voltage <5500 V	

Output Data

Output	P 42000 Dx TRMS-nnnn	0 ... 20 mA, 4 ... 20 mA and/or 0 ... 10 V to customer requirement, switchable
	P 42100 Dx TRMS-nnnn	0 ... 20 mA, 4 ... 20 mA or 0 ... 10 V fixed to customer requirement
Displacement	Up to 100 % as default	
Load	With output current	\leq 12 V (600 ohms at 20 mA)
	With output voltage	\leq 10 mA (1000 ohms at 10 V)
Residual ripple	<10 mVrms	

VariTrans® P 42000 D2/D3 TRMS

Specifications (continued)

Transmission Behavior

Gain error	<0.5 % full scale Gain error for sinusoidal input signals (crest factor $\sqrt{2}$) in the frequency range 45 ... 65 Hz	
Response T90	<150 msec rising <300 msec falling	
Influential factors (additional error)	Frequency 40 ... 1000 Hz	<1 % meas. val. (typ. 0.5 %)
	Crest factor 1... 3 (non-sinusoidal signals)	<0.5 % meas. val.
	Crest factor >3 ... 5	<1 % meas. val.
Common mode rejection ratio	CMRR	DC: approx. 150 dB AC 50 HZ, approx. 120 dB
	CMRR: Common-Mode Rejection Ratio = Differential voltage gain : Common-mode voltage gain	
Temperature influence	<100 ppm/K full scale Reference temperature for TC specifications = 23 °C, average TC is specified	

Power Supply

Power supply	20 ... 253 V AC/DC, AC 48 ... 62 Hz, approx. 2 VA; DC approx. 1.2 W
--------------	---

Isolation

Galvanic isolation	3-port isolation between input, output, and power supply	
Test voltage	Calibrated selection	10 kV AC input against output and power supply
	Fixed settings (Model P 42100 Dx TRMS-nnnn)	15 kV AC input against output and power supply
	All models	4 kV AC output against power supply
Working voltage (basic insulation) to EN 61010-1	Calibrated switching	Up to 2200 V AC/DC across input, output, and power supply with overvoltage category III and pollution degree 2 (fast transients: 13.5 kV)
	Fixed settings (Model P 42100 Dx TRMS-nnnn)	Up to 3600 V AC/DC across input, output, and power supply with overvoltage category III and pollution degree 2 (fast transients: 20 kV)
Rated isolation voltage to EN 50124-1	Calibrated switching	Up to 2200 V AC/DC across input, output, and power supply with overvoltage category III and pollution degree 2
	Fixed settings (Model P 42100 Dx TRMS-nnnn)	Up to 3600 V AC/DC across input, output, and power supply with overvoltage category III and pollution degree 2

Specifications (continued)

Protection against electric shock	Calibrated switching	<p>Safe Isolation to EN 61140 by reinforced insulation according to EN 61010-1.</p> <p>Working voltages with overvoltage category III and pollution degree 2:</p> <ul style="list-style-type: none"> - Up to 1100 V AC/DC across input, output, and power supply - Up to 300 V AC/DC across output and power supply
	Fixed settings (Model P 42100 Dx TRMS-nnnn)	<p>Safe Isolation to EN 61140 by reinforced insulation according to EN 61010-1.</p> <p>Working voltages with overvoltage category III and pollution degree 2:</p> <ul style="list-style-type: none"> - Up to 1800 V AC/DC across input, output, and power supply - Up to 300 V AC/DC across output and power supply <p>For applications with high working voltages, you should ensure there is sufficient spacing or isolation from neighboring devices and protection against electric shocks.</p>

Standards and Approvals

EMC	Product family standard	EN 61326
	Emitted interference	Class B
	Immunity to interference	Industry
	Slight deviations are possible while there is interference	

Other Data

Ambient temperature	Operation	-10 ... +70 °C	
	Operation with restricted data (on request)	-40 ... +85 °C	
	Transport and storage	-40 ... +85 °C	
Design	Modular housing	Housing width D2	45 mm
	With screw terminals	Housing width D3	67.5 mm
	See dimension drawings for further measurements		
Ingress protection	IP 40 enclosure, IP 20 terminals		
Fastening	With snap-on mounting for 35 mm top-hat rail according to EN 60715		
Weight	Type D2 approx. 350 g, type D3 approx. 500 g		

VariTrans® P 42000 D2/D3 TRMS

■ Application Example

Direct measurement of supply voltage

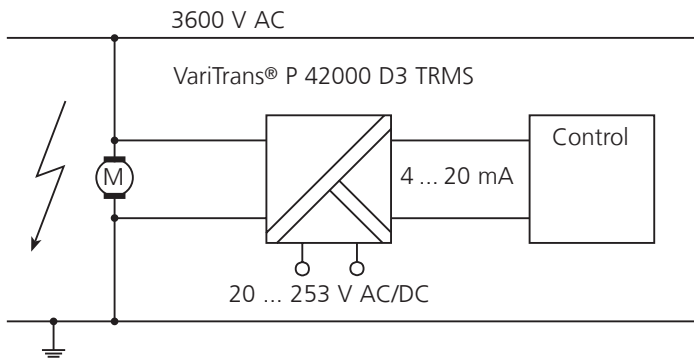

■ Dimension Drawings and Terminal Assignments

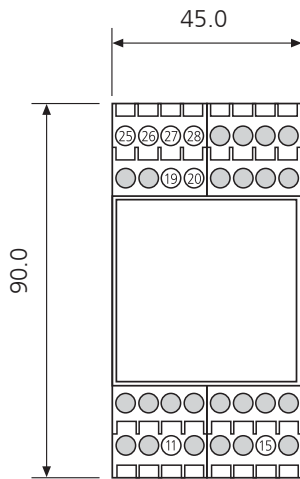

Type D2

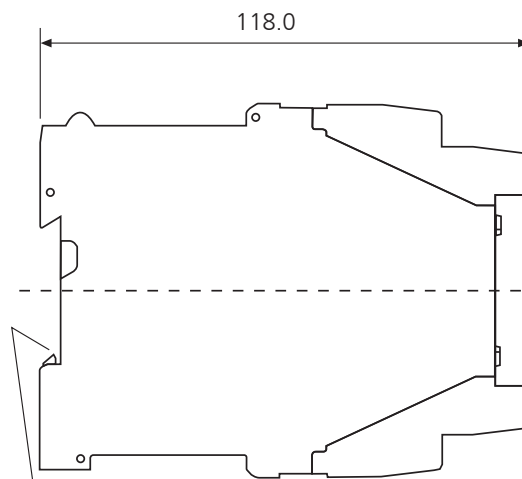

Snap-on mounting for 35 mm top hat rail EN 50 022

Please note: All dimensions in mm.

Terminal Assignments:

11 Input voltage 0
15 Input voltage ≤ 1200 V AC

19 AC/DC power supply
20 AC/DC power supply

37 DC output current/voltage +
38 DC output voltage +
39 DC output voltage -
40 DC output voltage +

M 3.5 connecting screws with self-releasing terminal housing
Conductor cross-section max. 1 x 4 mm² solid or 1 x 2.5 mm² stranded with sleeve, min. 1 x 0.5 mm² solid or stranded with sleeve

For switchable devices and voltage output, place jumper across terminals 37 and 38

Knick

■ Block Diagram

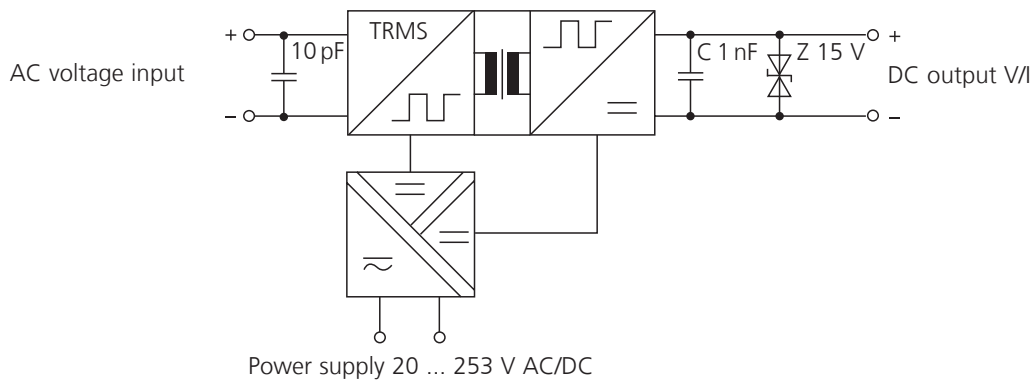

■ Dimension Drawings and Terminal Assignments

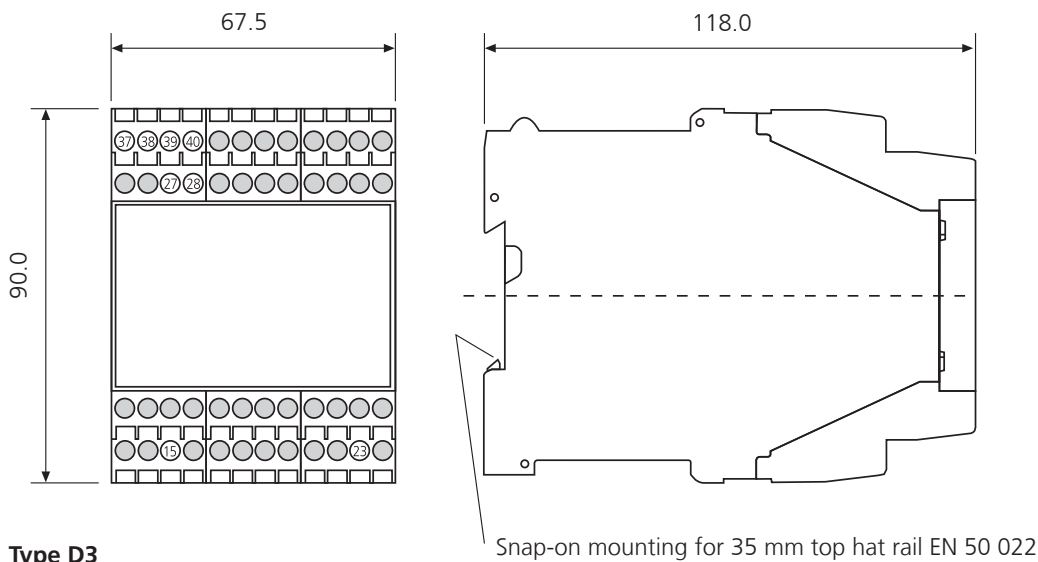

Type D3

Please note: All dimensions in mm.

Terminal Assignments:

15 Input voltage 0
23 Input voltage ≤ 3600 V AC

27 AC/DC power supply
28 AC/DC power supply

37 DC output current/voltage +
38 DC output voltage +
39 DC output voltage -
40 DC output voltage +

M 3.5 connecting screws with self-releasing terminal housing
Conductor cross-section max. 1 x 4 mm² solid or 1 x 2.5 mm² stranded with sleeve, min. 1 x 0.5 mm² solid or stranded with sleeve

For switchable devices and voltage output, place jumper across terminals 37 and 38



VariTrans® P 42000 TRMS AC/DC High-Voltage Transmitters With True RMS AC Input 0.1 A~ to 5 A~

Universal AC/DC high-voltage transmitter for sinusoidal and non-sinusoidal AC input signals in the range from 0.1 A to 5 A. True RMS value as standard-signal output for further processing in controllers or data acquisition systems. Calibrated selection of input and output.

■ Product Line

Devices	AC input	Output TRMS value	Working voltage	Test voltage	Order no.
VariTrans® P 43000 TRMS input and output selectable	0.1 A ... 5 A AC; 1 to 16 ranges to customer requirement	0 ... 20 mA, 4 ... 20 mA, and/or 0 ... 10 V, 1 to 16 ranges to customer requirement	≤2.2 kV AC/DC	10 kV AC	P 43000 D2 TRMS-nnnn
VariTrans® P 43100 TRMS input and output with fixed settings	0.1 A ... 5 A AC; to customer requirement	0 ... 20 mA, 4 ... 20 mA, or 0 ... 10 V, to customer requirement	≤3.6 kV AC/DC	10 kV AC	P 43100 D2 TRMS-nnnn

“Specific Test Report” included in shipment

Power supply

20 ... 253 V AC/DC



■ Specifications

Input Data

input	P 43000 D2 TRMS-nnnn	0.1 A ... 5 V AC; 1 to 16 customer-specific ranges, calibrated selection
	P 43100 D2 TRMS-nnnn	0.1 A ... 5 A AC; range fixed to customer requirement
Rated frequency	50/60 Hz	
Frequency range	40 ... 1000 Hz (frequency \leq 40 Hz on request)	
Input resistance	<0.6 ohm	
Input capacitance	Approx. 1 nF	
Overload	20 % full scale (max. crest factor 8)	

Output Data

Output	P 43000 D2 TRMS-nnnn	0 ... 20 mA, 4 ... 20 mA and/or 0 ... 10 V to customer requirement, switchable
	P 43100 D2 TRMS-nnnn	0 ... 20 mA, 4 ... 20 mA or 0 ... 10 V to customer requirement, fixed settings
Displacement	Up to 100 % as default	
Load	With output current	\leq 12 V (600 ohms at 20 mA)
	With output voltage	\leq 10 mA (1000 ohms at 10 V)
Residual ripple	<10 mVrms	

Transmission behavior

Gain error	<0.5 % full scale Gain error for sinusoidal input signals (crest factor $\sqrt{2}$) in the frequency range 45 ... 65 Hz		
Response T90	<150 msec rising <300 msec falling		
Influential factors (additional error)	Frequency 40 ... 1000 Hz	<1 % meas. val. (typ. 0.5 %)	
	Crest factor 1... 3 (non-sinusoidal signals)	<0.5 % meas. val.	
	Crest factor >3 ... 5	<1 % meas. val.	
Common mode rejection ratio	CMRR	DC: approx. 150 dB	AC 50 HZ, approx. 120 dB
	CMRR: Common-Mode Rejection Ratio = Differential voltage gain : Common-mode voltage gain		
Temperature influence	<50 ppm/K full scale Reference temperature for TC specifications = 23 °C, average TC is specified		

VariTrans® P 43000 D2 TRMS

Specifications (continued)

Power Supply

Power supply	20 ... 253 V AC/DC, AC 48 ... 62 Hz, approx. 2 VA; DC approx. 1.2 W
--------------	---

Isolation

Galvanic isolation	3-port isolation between input, output, and power supply	
Test voltage	Calibrated switching	10 kV AC input against output and power supply
	Fixed settings (Model P 43100 D2 TRMS-nnnn)	15 kV AC input against output and power supply
	All models	4 kV AC output against power supply
Working voltage (basic insulation) to EN 61010-1	Calibrated switching	Up to 2200 V AC/DC across input, output, and power supply with overvoltage category III and pollution degree 2 (fast transients: 13.5 kV)
	Fixed settings (Model P 43100 D2 TRMS-nnnn)	Up to 3600 V AC/DC across input, output, and power supply with overvoltage category III and pollution degree 2 (fast transients: 20 kV)
Rated isolation voltage to EN 50124-1	Calibrated switching	Up to 2200 V AC/DC across input, output, and power supply with overvoltage category III and pollution degree 2
	Fixed settings (Model P 43100 D2 TRMS-nnnn)	Up to 3600 V AC/DC across input, output, and power supply with overvoltage category III and pollution degree 2
Protection against electric shock	Calibrated switching	Safe Isolation to EN 61140 by reinforced insulation according to EN 61010-1. Working voltages with overvoltage category III and pollution degree 2: - Up to 1100 V AC/DC across input, output, and power supply - Up to 300 V AC/DC across output and power supply
	Fixed settings (Model P 43100 D2 TRMS-nnnn)	Safe Isolation to EN 61140 by reinforced insulation according to EN 61010-1. Working voltages with overvoltage category III and pollution degree 2: - Up to 1800 V AC/DC across input, output, and power supply - Up to 300 V AC/DC across output and power supply

For applications with high working voltages, you should ensure there is sufficient spacing or isolation from neighboring devices and protection against electric shocks.

Specifications *(continued)*

Standards and Approvals

EMC	Product family standard	EN 61326
	Emitted interference	Class B
	Immunity to interference	Industry
	Slight deviations are possible while there is interference	

Other Data

Ambient temperature	Operation	-10 ... +70 °C
	Operation with restricted data (on request)	-40 ... +85 °C
	Transport and storage	-40 ... +85 °C

Design	Modular housing	Housing width D2	45 mm
	With screw terminals	See dimension drawings for further measurements	

Ingress protection	IP 40 enclosure, IP 20 terminals
--------------------	----------------------------------

Fastening	With snap-on mounting for 35 mm top-hat rail according to EN 60715
-----------	--

Weight	Approx. 350 g
--------	---------------

VariTrans® P 43000 D2 TRMS

■ Application Example

Direct current measurement with a high input potential

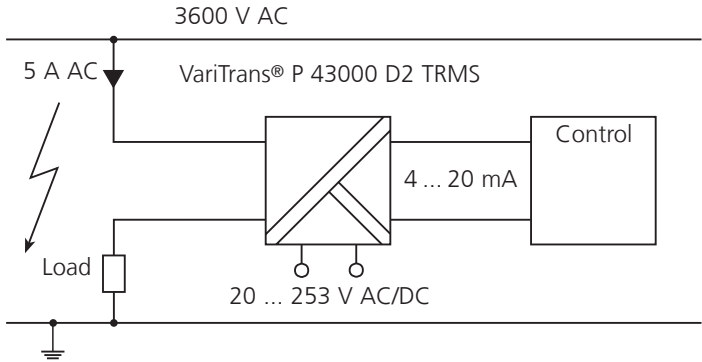

■ Block Diagram

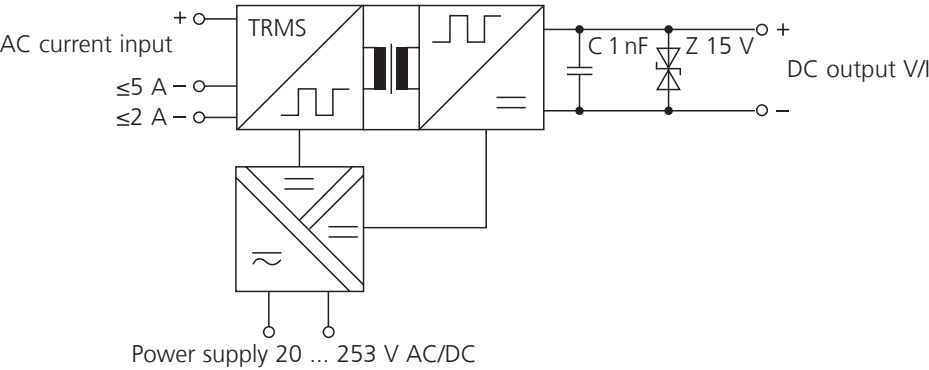

■ Dimension Drawings and Terminal Assignments

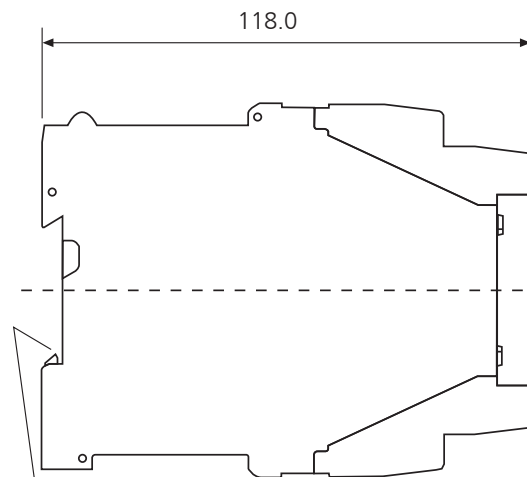
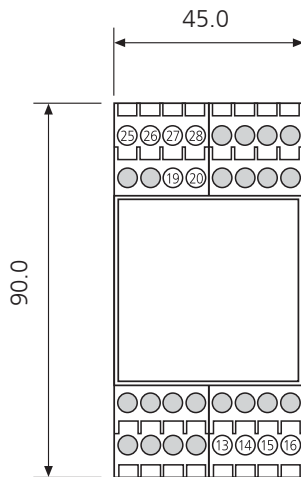

Snap-on mounting for 35 mm top hat rail EN 50 022

Please note: All dimensions in mm.

Terminal Assignments:

Input 1 ... 5 A

- 13 n. c.
- 14 Input current \pm
- 15 Input current 0 (≤ 5 A)
- 16 Input current 0 (≤ 2 A)

- 19 AC/DC power supply
- 20 AC/DC power supply

- 25 Output current/voltage +
- 26 Output voltage +
- 27 Output current -
- 28 Output voltage -

Input 0.1 ... 5 A

- 13 +0.1 A ... +1 A
- 14 +2 A ... +5 A
- 15 -2 A ... -5 A
- 16 -0.1 A ... -1 A

- 19 AC/DC power supply
- 20 AC/DC power supply

- 25 Output current/voltage +
- 26 Output voltage +
- 27 Output current -
- 28 Output voltage -

M 3.5 connecting screws with self-releasing terminal housing
Conductor cross-section max. 1 x 4 mm² solid or 1 x 2.5 mm² stranded with sleeve,
min. 1 x 0.5 mm² solid or stranded with sleeve

For switchable devices and voltage output, place jumper across terminals 25 and 26

Isolation Amplifiers
Transmitters

Indicators

Process Analytics

Portable Meters

Laboratory Meters

Sensors

Fittings

Knick 

**Knick Elektronische Messgeräte
GmbH & Co. KG**

Beuckestraße 22, 14163 Berlin, Germany

Phone: +49 (0)30-801 91-0

Fax: +49 (0)30-801 91-200

knick@knick.de · www.knick.de