

The 6 mm class.

Active and passive standard signal isolators, repeater power supplies, and signal doublers in ultra-slim housings.

Isolation Amplifiers
Transmitters

Indicators

Process Analyzers

Portable Meters

Laboratory Meters

Sensors

Fittings







Knick 

Knick

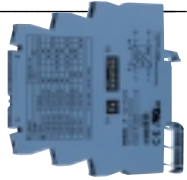

Contents:

	Page
<p>The reference. Knick technology in electrical isolation.</p>	4
<p>The 6 mm class from Knick. New, ultra-slim Knick standard signal isolators for all standard applications at a glance.</p>	6
<p>VariTrans® A 20000 Standard-signal isolator with calibrated range selection and safe isolation</p> 	8
<p>VariTrans® B 10000 Standard-signal isolator with calibrated range selection</p> 	14
<p>VariTrans® A 20300 Signal doublers with 2 calibrated switchable outputs, also for load increase</p> 	20
<p>IsoTrans® A 20400 Passive standard-signal isolator, 1- and 2-channel</p> 	26
<p>IsoAmp® PWR A 20100 Compact repeater power supply with calibrated range selection and safe isolation, HART</p> 	32
<p>IsoAmp® PWR B 10116 Compact repeater power supply</p> 	38

The reference.



Knick technology in electrical isolation.

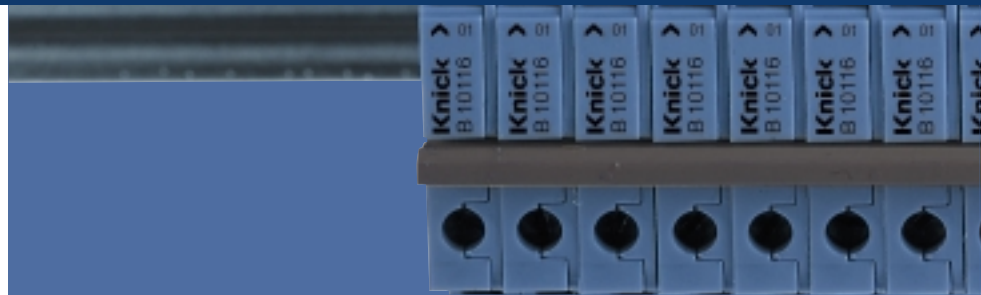

■ Vision and tradition

In the history of industrial measurement engineering Knick has implemented many technical improvements and innovations for the development of electronic measuring instruments. Back in 1945, the world's first high-precision zero-point-stabilized DC amplifier was developed and manufactured. In the following years a comprehensive product range was developed. The term "Knick amplifier" became a synonym for high-quality processing and isolation of direct current and direct voltage signals. Today, company policy still focuses on a high technical level and a highly innovative orientation. The product design leaves nothing to chance. Every detail serves the purpose of maximizing performance. Therefore, Knick instruments always provide a large number of patented features with substantial advantages for the user.

■ Safety as a constructive aim

Then, like today, the involved engineers had a central aim: trend-setting innovations in the field of safety. Aspects of safety and reliability are taken into consideration as early as in the first definition phase of the development stage. Exact knowledge of the conditions of use and the

expected operational demands is implemented precisely.

The consistent use of high-quality components with an extremely long service life is part of Knick's basic design principles just as intelligent circuit design and the planning of safety margins between the actual load and possible maximum load. Comprehensive reliability tests ensure that the specified product properties as well as the specifications of all currently applicable standards and draft standards are consistently met. This makes the devices optimally suitable even for roughest industrial environments.

In addition to the use of state-of-the-art technologies, the main focus is on preventive quality assurance in production. One result of this perfection is the proverbial long life of Knick isolators that sets standards with a 5-year warranty and MTBF values of several hundred years. Not by chance but as an expression of technological performance.

■ Pacemaker: The 6 mm class

With its 6 mm class, Knick presents a product line which provides unequaled features and capabilities. Outstanding performance in every aspect makes these isolators unique. Knick initialized this technological change in 2001

by introducing the VariTrans® B 10000 standard-signal isolators – now the reference standard in the compact class. Up to now, the product line of 6 mm isolators has been increased by devices with safe isolation, signal doublers and standard-signal isolators with high output load, passive standard-signal isolators, as well as repeater power supplies with signal conversion.

Particular attention is paid to energy efficiency. Power loss and the resulting self-heating are extremely reduced so that outstanding values for reliability and service life are obtained – the MTBF for the passive standard-signal isolators is 1200 years.

This uncompromising reduction of energy consumption is supported by an "intelligent" connection of power supply: Controlled by a "power management" the power consumption is adapted to the currently required output power. In this way, the standard-signal isolator can drive a load of 20 V (1000 ohms at 20 mA) – with the outputs connected in series.

Thanks to the signal transmission concept, no sense resistors are required for direct current transmission. This patented technique provides excellent measurement accuracy and ensures an outstanding long-term stability.



■ Interference-free functionality

Passive isolators provide maximum reliability and high accuracy and are easy to install. Smallest dimensions and an optimal price-performance ratio are achieved due to the omission of power supply components. Up to now, application of this device class has been restricted because the devices were not interference-free. Often, they were not even used for undemanding applications or when the loads were known, so that the price and performance advantages could not be exploited.

Now Knick has considerably expanded the application possibilities of passive isolators by implementing a Bürdenstop® (load stop) function. Here, the current supplied at the primary side is maintained independently from the output load. Thus, for the first time any excessive load increase at the output, such as caused by line breakage or in-constant loads including complex impedances, can be compensated for.

The 6 mm passive isolators of the A 20400 series are available with or without Bürdenstop®. When the output load (input resistance of the controller) is up to 60 ohms, a passive isolator with Bürdenstop® is the best solution.

■ Calibrated range selection

The desire for standardization and flexible signal conversion is satisfied through a range selection which makes on-site calibration unnecessary. Adjustments using screwdriver, calibrator, or multimeter are omitted. There are no stability problems due to instable trim components – e. g. potentiometers. Configuration is made with DIP switches, ensuring quick and safe operation. The configuration can be noted on the device.

■ Excellent large-signal characteristics

Isolation amplifiers are mainly used for d.c. current signals, but the correct transmission of fast signal changes cannot be dispensed with. Excellent large-signal characteristics guarantee a correct run into the overrange limit. Dead times, hysteresis, signal reversal, or latch-up effects are prevented – an indispensable feature for further processing in the PLC.

■ True 3-port isolation

In spite of the reduced space, the 6 mm class provides true 3-port isolation between input, output, and power supply to prevent parasitic voltages. Safe isolation according to EN 61140 for working voltages up to 300 V AC/DC is unique for this device class. It guarantees best possible protection of personnel and equipment. Test voltage is up to 2.5 kV. International use of the 6 mm class is ensured by UL and CSA approvals.

■ Advantageous assembly

Also the practical use has not been forgotten. The inputs are protected against inverse polarity and the inputs and outputs are provided with overload protection to prevent damage caused by inappropriate installation. A pluggable cross-connection for power supply enables quick and therefore inexpensive mounting. The extremely compact design enables the installation of up to 32 channels on an only 10 cm long top hat rail. The units can of course be mounted closely in series on the mounting rail.



The 6 mm class.

Knick >

VariTrans®

IsoAmp®

IsoTrans®



At a glance:

New, ultra-slim Knick isolators for all standard applications.

High performance in a small space:

- 3-port isolation (input against output against power supply)
- Safe isolation up to 300 V according to EN 61140
- Test voltage up to 2500 V
- Calibrated range selection – no tedious adjustments
- Simple configuration – DIP switches accessible from outside
- Extremely low power loss – closely spaced series connection on mounting rail
- MTBF of 1200 years – reliable function in the long term
- International use – UL/CSA approvals
- Best price/performance ratio
- 5-year warranty

■ 6 mm: Active standard-signal isolators

For galvanic isolation of 0 ... 10 V, 0 ... 20 mA, or 4 ... 20 mA standard signals.

For preventing a mutual or external influence of measuring signals in a system. Additional protection of persons and systems through safe isolation according to EN 61140.

Predestined for the separation of PLC input and output circuits. Conversion of signals if required – e. g. when a current signal from the field is to be connected to a PLC voltage input. When a live zero signal has to be transformed into a dead zero signal. Or when other standard signal combinations are required.



■ 6 mm: Signal doublers and standard-signal isolators with high output load

For converting one standard signal into two galvanically isolated standard signals. Splitting into two separate circuits prevents controllers, actuators, indicators, or recording equipment from mutual influence or damage. The signal doublers transform voltage signals (0 ... 10 V) or current signals (0 or 4 to 20 mA) into two current signals (0 or 4 to 20 mA). The calibrated ranges are selected with DIP switches.

They can also be used where a high load (up to 1000 ohms) must be driven. A simple series connection of the two current outputs can provide a voltage of up to 20 V at 20 mA. This application allows the input signal (0 ... 10 V, 0 or 4 to 20 mA) to be converted into the required output current signal (0 or 4 to 20 mA).





■ **6 mm:**
**Passive standard-signal
 isolators**

Loop-powered standard-signal isolators provide a cost-favorable solution for isolation of 0 ... 20 mA or 4 ... 20 mA signals as no effort is required for power supply units and their wiring.

The use of passive isolators is frequently limited by feedback from the output to the input in the event of errors. This limitation is eliminated with Bürdenstop® – the isolator is reactionless.

Bürdenstop® can be used when the load at the output is known and small, as is the case for PLC inputs.

Available as a one- or two-channel version in 8-pin 6-mm housing, with and without Bürdenstop®.

Up to 320 channels can be mounted per meter top-hat rail allowing an extremely high packing density.



■ **6 mm:**
**Repeater power supplies
 with signal conversion**

For galvanically isolated supply of 2-wire sensors and transmitters.

If required, available with adaptation of the output signal to different standard signal inputs of a controller, plus HART transmission.

Sensors fed through a current loop are frequently supplied from a PLC module or by a common power supply unit. Disadvantage: Galvanic isolation of the circuits from each other is not guaranteed – mutual influence must be expected.

Because a falsified measurement signal involves incalculable risks for the operation of the system, galvanic isolation of the sensor circuits from each other is absolutely advisable.

The new 6 mm repeater power supplies offer very economical solutions here.



VariTrans® A 20000

Knick >

■ **The VariTrans® A 20000 high-performance isolation amplifier by Knick reliably isolates, transmits, and converts 0(4) ... 20 mA and 0 ... 10 V standard signals with calibrated range switching providing safe isolation to EN 61140.**



The task

Isolation and conversion of 0 ... 20 mA, 4 ... 20 mA, as well as 0 ... 10 V standard signals with high demands to measurement accuracy. At the same time, best possible protection of personnel and equipment must be guaranteed.

The problem

Safe isolation as per EN 61140 is required according to the standards governing the erection of installations. The tightly dimensioned installation space on the top-hat rail must be optimally used. Procurement logistics and stockkeeping call for a universal product which covers all common signal combinations.

The solution

In spite of its just 6 mm narrow modular housing, the new VariTrans® A 20000 meets the requirements of EN 61140 regarding safe isolation up to a working voltage of 300 V. Test voltage is 2.5 kV. Very small leakage capacitances also ensure that high transient common-mode interferences can be reliably isolated and do not lead to system malfunctions.

Standardization and flexible signal conversion are optimally implemented by the calibrated range selection – on-site calibration becomes superfluous.

The housing

The just 6 mm-wide modular housing allows high component density in the switch cabinet. Connection of power supply is facilitated by a simple-to-install cross-connection comb which can be cut to length as required.

The advantages

3-port isolation allows universal usability. The input and output circuits can be applied to any potentials, taking account of the permitted working voltages. The distinction between input and output isolation amplifier is not required with the VariTrans® A 20000 because all 3 electric circuits are galvanically isolated from each other.

The technology

Knick achieves a significant increase in reliability and service life through the development of isolation amplifiers with extremely low power consumption and low self-heating. This leads to a significant increase in the reliability and service life of the electronic components – for example, the MTBF (Mean Time Between Failures) of the new VariTrans® A 20000 isolation amplifier is 440 years.

As the design of the electrical isolation also takes the requirements of EN 61131-2 into account, the isolator is predestined for PLC applications.

Isolation amplifiers are mainly used for d. c. current signals, but the correct transmission of fast signal changes cannot be dispensed with. Excellent large-signal characteristics guarantee a correct run into the overrange limit. Dead times, hysteresis, signal reversal, or latch-up effects are prevented – an indispensable feature for further processing in the PLC.

Warranty: 5 years

Defects occurring within 5 years from delivery date shall be remedied free of charge at our plant (carriage and insurance paid by sender).

The facts:

3-port isolation
in a 6 mm housing

Personnel and equipment protection conforming to standards
Safe electrical isolation according to EN 61140

Best price/performance ratio
High accuracy and isolation – 2.5 kV test voltage

Low-cost installation
Convenient power supply through pluggable cross-connections

Cost reduction by smaller switch cabinets
More channels per meter top hat rail thanks to space-saving 6 mm housing and closely spaced series connection

Long service life
Extremely low failure rate (MTBF of 440 years) due to reduced self-heating

High accuracy and temperature stability
Gain error 0.2 % meas. val. and temperature coefficient 0.01 %/K

Calibrated range selection
without complicated adjustments

Simple configuration
DIP switches, accessible from the outside

Adjustable or fixed range models

International use
UL/CSA approval

5-year warranty

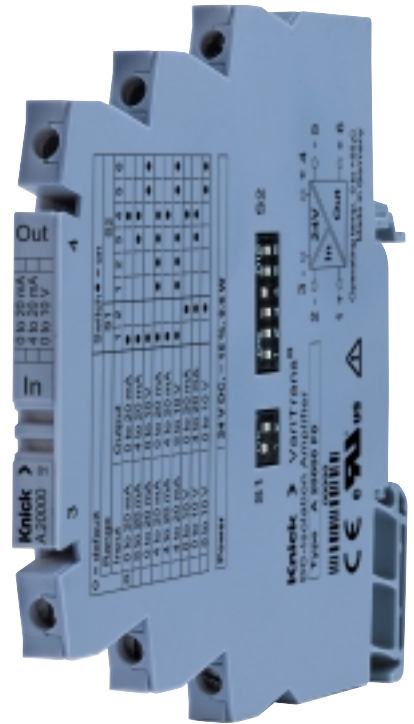

Product line

Devices	Input	Output	Order no.
VariTrans® A 20000 Input and output with calibrated switching	0 ... 20 mA	0 ... 20 mA	A 20000 F0
	4 ... 20 mA	4 ... 20 mA	
	0 ... 10 V	0 ... 10 V	
VariTrans® A 20000 Fixed settings	0 ... 20 mA	0 ... 20 mA	A 20016 F0
	0 ... 20 mA	4 ... 20 mA	A 20017 F0
	0 ... 20 mA	0 ... 10 V	A 20018 F0
	4 ... 20 mA	0 ... 20 mA	A 20026 F0
	4 ... 20 mA	4 ... 20 mA	A 20016 F0
	4 ... 20 mA	0 ... 10 V	A 20028 F0
	0 ... 10 V	0 ... 20 mA	A 20036 F0
	0 ... 10 V	4 ... 20 mA	A 20037 F0
	0 ... 10 V	0 ... 10 V	A 20038 F0
	Cross-connections	Pluggable cross-connection for looping through of power supply for up to 41 power supply connections of B 10XXX F0 and A 20XXX F0	
Power supply	24 V DC		

VariTrans® A 20000

■ Specifications

Input data

Inputs	0 ... 20 mA 4 ... 20 mA 0 ... 10 V	switchable (factory setting 0 ... 20 mA)
Input resistance	Current input: Voltage input:	Voltage drop <0.1 V at 20 mA Approx. 100 kohms
Overload	Current input: Voltage input:	<100 mA Voltage limited to 30 V with suppressor diode, max. permitted permanent current 3 mA

Output data

Outputs	0 ... 20 mA 4 ... 20 mA 0 ... 10 V	switchable (factory setting 0 ... 20 mA)
Load	With output current: With output voltage:	≤ 10 V (≤ 500 ohms at 20 mA) ≤ 1 mA (≥ 10 kohms at 10 V)
Offset	<20 μ A or <10 mV	
Residual ripple	<10 mV _{rms}	

Transmission behavior

Gain error ¹⁾	<0.2 % meas. val. with direct 1:1 current transmission <0.3 % meas. val. with voltage input and/or voltage output
Temperature influence ²⁾	<0.01 %/K full scale (reference temperature 23 °C)
Cut-off frequency	>100 Hz, -3 dB

Power supply

Power supply	24 V DC (± 15 %), approx. 0.6 W Power supply can be routed from one device to another via cross-connections.
--------------	--

■ Specifications, continued

Isolation

Test voltage	2.5 kV~, 50 Hz
Working voltage (basic insulation)	Up to 300 V AC/DC across input and output/power supply with overvoltage category II and pollution degree 2, up to 100 V AC/DC across output and power supply with category II and degree 2 according to EN 61010 Part 1.
Protection against electrical shock	Safe isolation up to 300 V across input and output/power supply according to EN 61140 by reinforced insulation in accordance with EN 61010 Part 1 with overvoltage category II and pollution degree 2. For applications with high working voltages, you should ensure there is sufficient spacing or isolation from neighboring devices and protection against electrical shocks.
EMC ³⁾	Product standard: EN 61326 Emitted interference: Class B, Immunity to interference: Industry
Approvals	cURus, File No. E 220033 Standards: UL 508 and CAN/CSA 22.2 No. 14

Further data

Ambient temperature	Operation: 0 ... +55 °C when mounted in row Storage: -40 ... +85 °C
Design	Modular housing with screw terminals, power supply also possible via cross-connections 6.1 mm wide, see dimension drawing
Protection class	IP 20
Mounting	For 35 mm top hat rail to EN 60715
Weight	Approx. 50 g

1) Additional error during live-zero operation 20 µA or 10 mV

2) Average TC in specified operating temperature range 0 °C ... +55 °C

3) Slight deviations are possible during interference

VariTrans® A 20000

■ Typical application

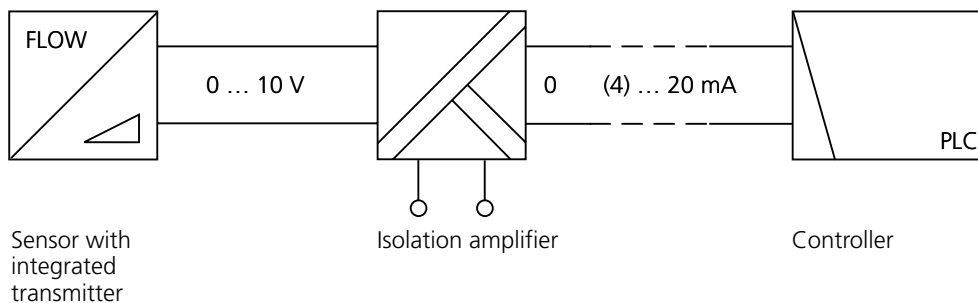

■ Electrical isolation of PLC systems

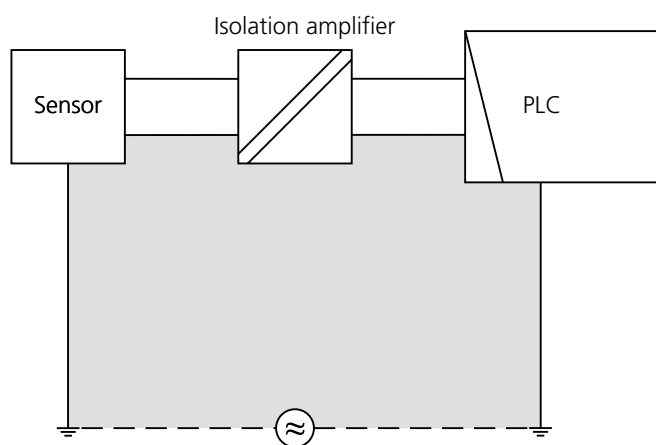

■ Schematic diagram

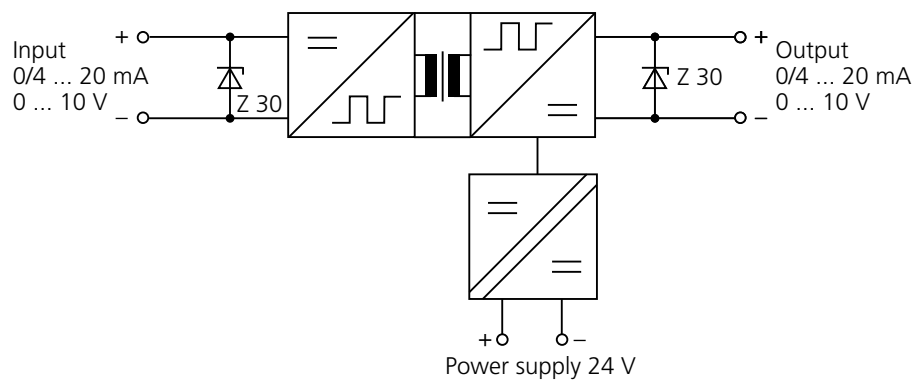

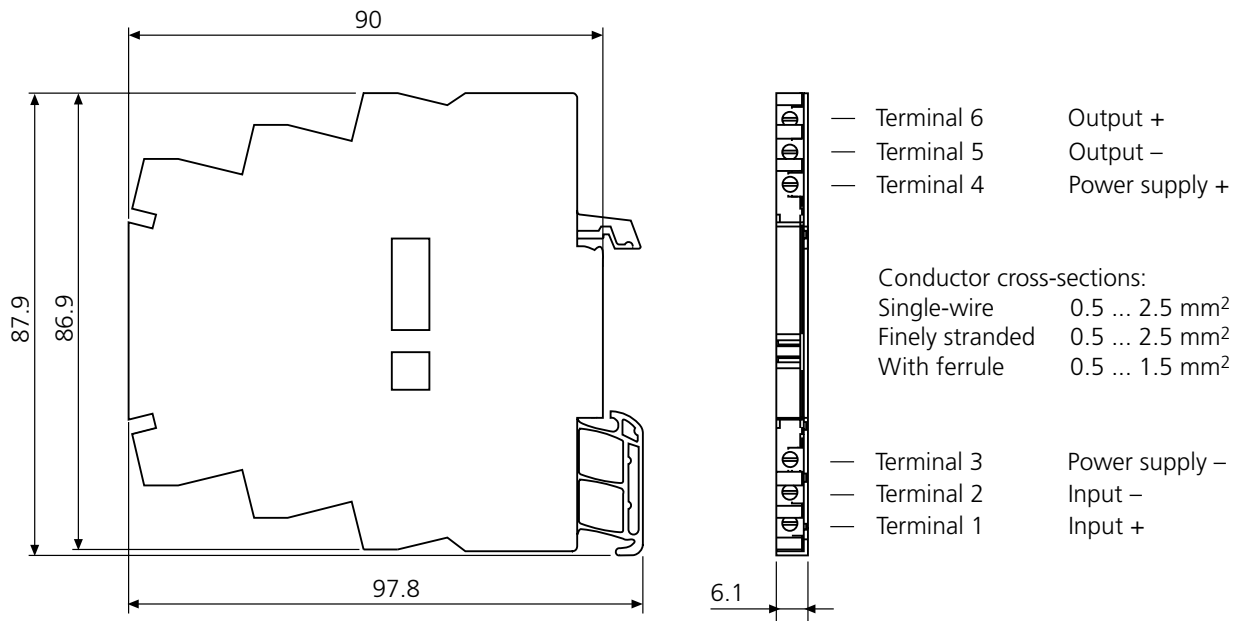
Knick >**■ Dimension drawing and terminal assignments**

All dimensions in mm.

VariTrans® B 10000

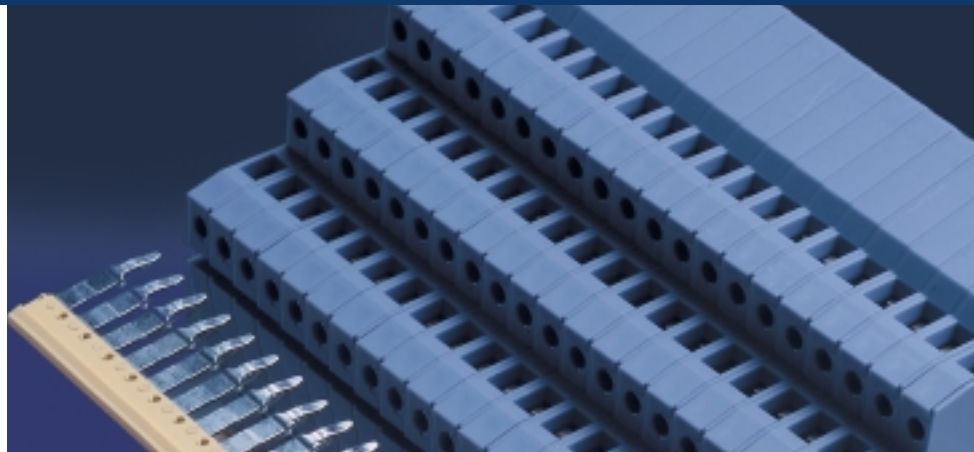

■ **The world's first 3-port standard signal isolator in a 6 mm modular housing.**

The task

Isolation and, if required, conversion of 0 ... 20 mA, 4 ... 20 mA, and 0 ... 10 V standard signals. If space and budget are limited, there could still be difficulties when it comes to selecting a suitable isolator despite the standard transmission requirements.

The problems

Up to now the only way of reducing costs substantially was to opt for low quality products. As a large number of different signals also required a large number of isolators, this also led to considerable stock-keeping costs.

The solution

With its extreme compactness and low self-heating, the new standard-signal isolator from Knick sets new standards. The VariTrans® B 10000 is available with 9 selectable, calibrated ranges or as one of eight different variants with fixed settings. In any case, the price is extremely attractive.

The housing

Measuring only 6 mm, the closed, ultra-slim modular housing of the VariTrans® B 10000 allows up to 163 active isolation amplifiers per meter top-hat rail.

A pluggable cross-connection for power supply ensures quick and therefore inexpensive mounting.

The advantages

In spite of the reduced space, the VariTrans® B 10000 provides true 3-port isolation between input, output, and power supply to prevent parasitic voltages.

The technology

Analog signal processing with transformer isolation ensures excellent signal transmission. The input and output ranges can easily be selected using DIP switches.

The facts:

Safety in the smallest space

3-port isolation in a 6 mm housing

Cost reduction by smaller switch cabinets

More channels per meter top hat rail thanks to space-saving 6 mm housing and closely spaced series connection

Attractive price

One of the cheapest high-quality isolators on the market

Reliable function in the long term

Extremely low failure rate (MTBF of 440 years) due to reduced self-heating

Good accuracy

Exemplary signal transmission for standard applications

Low-cost installation

Pluggable cross-connections allow easy and extremely cost-efficient connection of power supply to several VariTrans® B 10000 units

Calibrated range selection

No tedious readjustment

Simple configuration

DIP switches accessible from the outside

8 fixed-range models

If range shifting is to be avoided

International use

UL/CSA approval

5-year warranty

Warranty: 5 years

Defects occurring within 5 years from delivery date shall be remedied free of charge at our plant (carriage and insurance paid by sender).

■ **Product line**

Devices	Input	Output	Order no.
B 10000 with calibrated input and output selection	0 ... 20 mA, 4 ... 20 mA, 0 ... 10 V	0 ... 20 mA, 4 ... 20 mA, 0 ... 10 V	B 10000 F0
B 10000 with fixed settings	0 ... 20 mA 0 ... 20 mA 0 ... 20 mA 4 ... 20 mA 4 ... 20 mA 4 ... 20 mA 0 ... 10 V 0 ... 10 V 0 ... 10 V	0 ... 20 mA 4 ... 20 mA 0 ... 10 V 0 ... 20 mA 4 ... 20 mA 0 ... 10 V 0 ... 20 mA 4 ... 20 mA 0 ... 10 V	B 10016 F0 B 10017 F0 B 10018 F0 B 10026 F0 B 10016 F0 B 10028 F0 B 10036 F0 B 10037 F0 B 10038 F0
Cross-connections	Pluggable cross-connection for looping through of the power supply for up to 41 power supply connections of the B 10XXX F0 und A 20XXX F0, splittable.		ZU 0542

Power supply

24 V DC

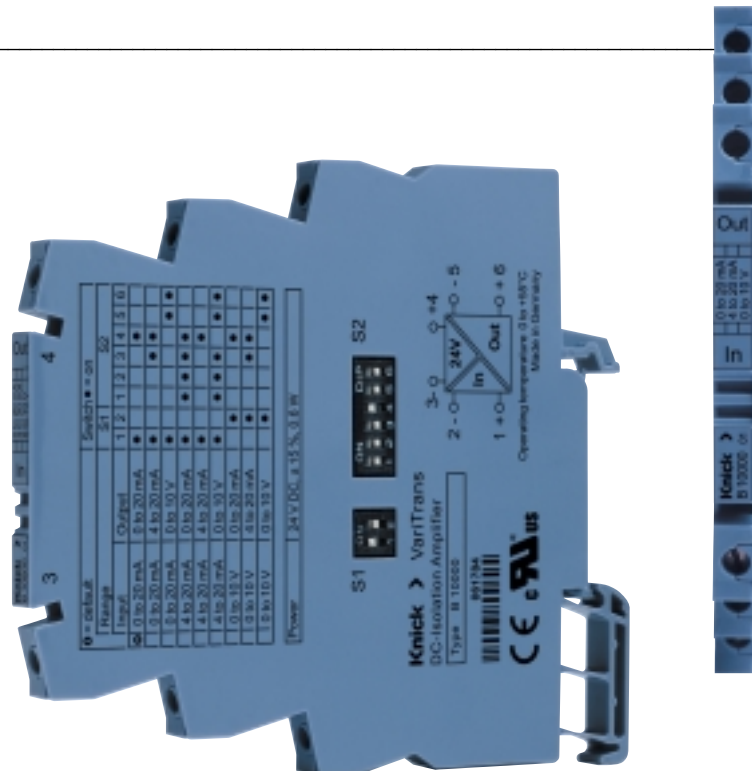

VariTrans® B 10000

■ Specifications

Input data

Inputs	0 ... 20 mA 4 ... 20 mA 0 ... 10 V	Calibrated selection or fixed settings (see Product line)
Input resistance	Current input: Voltage input:	Voltage drop <0.1 V at 20 mA Approx. 100 kohms
Overload	Current input: Voltage input:	<100 mA Voltage limited to 30 V by suppressor diode, max. permitted permanent current 3 mA

Output data

Outputs	0 ... 20 mA 4 ... 20 mA 0 ... 10 V	Calibrated selection or fixed settings (see Product line)
Load	With output current: With output voltage:	≤ 10 V (≤ 500 ohms at 20 mA) ≤ 1 mA (≥ 10 kohms at 10 V)
Offset	<20 μ A or <10 mV	
Residual ripple	<10 mV _{rms}	

Transmission behavior

Gain error ¹⁾	<0.3 %
Cut-off frequency	>100 Hz –3 dB
Temperature influence ²⁾	<0.01 %/K full scale (reference temperature 23 °C)

Power supply

Power supply	24 V DC (± 15 %), approx. 0.6 W Power supply can be routed from one device to another via cross-connections.
--------------	--

Isolation

Galvanic isolation	3-port isolation between input, output, and power supply
Test voltage	510 V AC

■ Specifications, continued

Isolation

Working voltage (basic insulation) 100 V with overvoltage category II and pollution degree 2 according to EN 61010-1. For applications with high working voltages, you should ensure there is sufficient spacing or isolation from neighboring devices and protection against electrical shocks.

Standards and Approvals

EMC²⁾ Product standard: EN 61326, emitted interference: Class B, Immunity to interference: Industry

Approvals cURus, File No. E 220033, Standards: UL 508 and CAN/CSA 22.2 No. 14-95

Further data

Ambient temperature Operation: 0 ... +55 °C
Transport and storage: -25 ... +85 °C

Design Modular housing with screw terminals, 6.1 mm wide, see dimension drawing

Protection class IP 20

Mounting For 35 mm top-hat rail to EN 60715
See dimension drawing for conductor cross-section

Weight Approx. 50 g

- 1) Additional error in live-zero operation 20 µA or 10 mV
- 2) Average TC in specified operating temperature range 0 °C ... +55 °C
- 3) Slight deviations are possible during interference

■ Schematic diagram

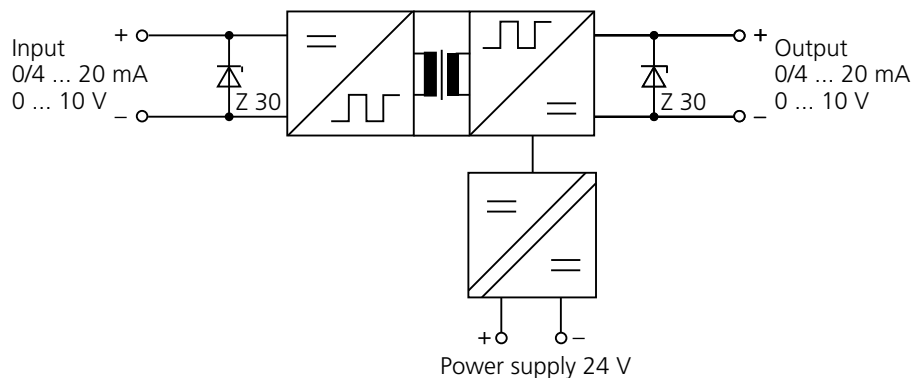

VariTrans® B 10000

■ Typical applications

Electrical isolation

for safe coupling of the measured signals to the evaluation electronics

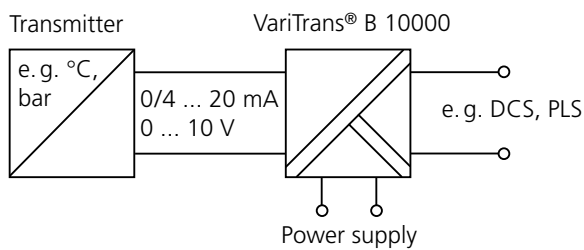

Signal conversion

For example, conversion of voltage signals into current signals for interference-free signal transmission over long distances

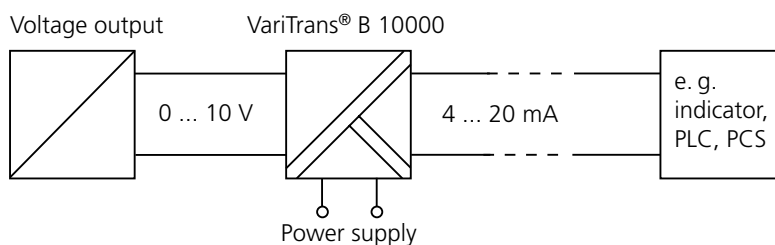

Load increase

e.g. for measuring signals with low load capability

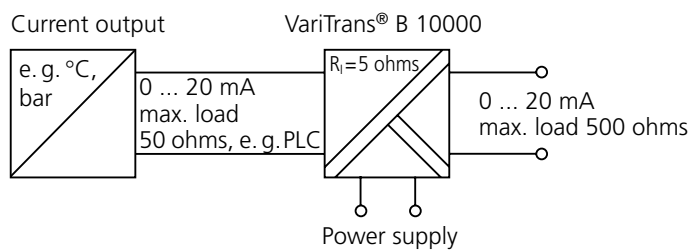

■ **Dimension drawing and terminal assignments**

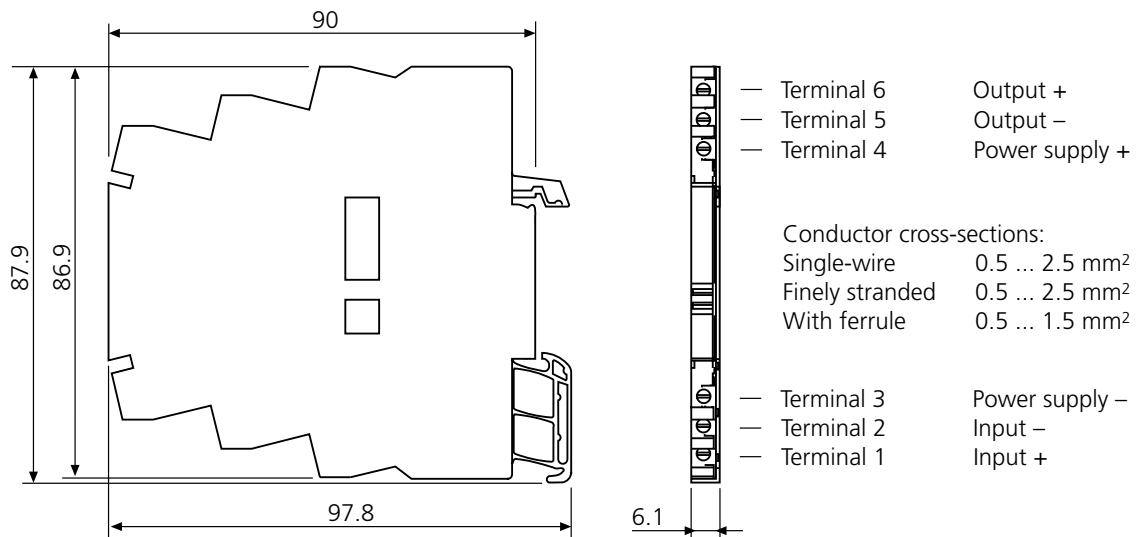

All dimensions in mm.

VariTrans® A 20300



■ **Signal doublers with two calibrated switchable outputs in a 6 mm housing, also for applications with high-level output loads.**



The task

Isolation and transmission of 0 (4) ... 20 mA and 0 ... 10 V standard signals in two 0(4) ... 20 mA output channels with galvanic isolation between input, output, and power supply.

The problems

Measuring and control engineering frequently requires an analog standard signal to be processed at two points, i. e. by two devices, whereby both devices are to recognize the signal. To prevent falsified signals and interaction or even damage, in particular in the event of errors, it makes sense to isolate signals and devices galvanically from one another.

The solution

The VariTrans® 20300 signal doubler is an extremely compact product which allows cost-efficient solutions. Using this unit, input, both outputs, and power supply are decoupled from one another (4-port isolation).

The housing

Measuring only 6 mm, the ultra-slim, closed 8-pin modular housing of the VariTrans® A 20300 takes up only a little space on the top hat rail and, if necessary, can be installed at a later date.

The advantages

As a signal doubler:

In addition to "doubling" the analog signal, the VariTrans® A 20300 can also convert signals if required. For example, if the signal source has only one voltage output but the installation uses current signals, the signal doubler converts the voltage signal (0 ... 10 V) proportionally into the required current signals (0 ... 20 mA or 4 ... 20 mA). An adjustment from "Dead Zero" (0 ... 20 mA) to "Live Zero" (4 ... 20 mA) is also possible. The corresponding input and output signals can be calibrated and selected using DIP switches whereby the two outputs are switched over together.

For load increase:

The VariTrans® A 20300 may also be used when a particularly high output load is required. Standard signal sources can often drive a load of up to 500 ohms, i. e. supply 10 V at 20 mA. Sometimes certain devices – e. g. actuators – require a higher voltage, i. e. their input resistance is higher. Likewise in this case, the signal doubler can solve the problem: both output signals are now not used separately but are connected in series to form one signal. The available voltage is

then doubled allowing an increased load up to 1000 ohms (20 V at 20 mA). Of course, the current which determines the 0/4 to 20 mA signal is not changed.

The technology

To implement the high functionality of an A 20300 in the smallest of spaces – in a 6 mm wide modular housing with correspondingly small volume – a patented switching technology is used. The energy balance (2 active outputs) in particular must be optimized for all operating conditions. An application for patent has been filed for the switching principles of the VariTrans® A 20300.

Like all products in the VariTrans® A 20XXX series, the signal doubler also provides safe isolation in accordance with EN 61140 to ensure high-level protection of persons and installations. This is achieved by means of increased insulation in compliance with EN 61010-1. In spite of being only 6 mm wide, the VariTrans® A 20300 makes no compromises regarding its insulation properties.

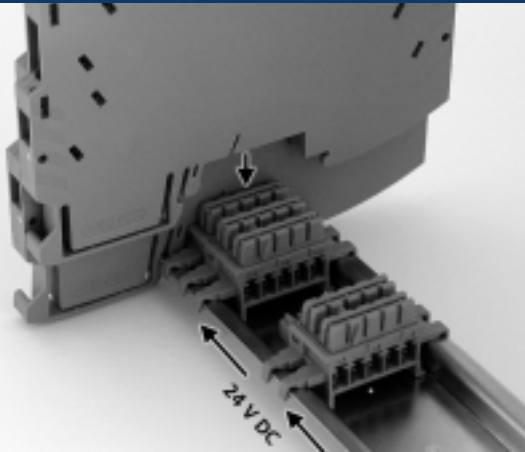

◀ The power supply can be routed from one device to another via DIN rail bus connectors.



The facts:

Safety in the smallest space
4-port isolation in a 6 mm modular housing

Signal doubling
combined with signal conversion

Load increase up to 1000 ohms
possible for inputs with high input impedances

Personal protection
through safe electrical isolation according to EN 61140

Flexible use
with DIP switches accessible from the outside

Calibrated range selection
without complicated adjustments

Low-cost solution
Only one compact, low-cost device is required instead of 2 conventional isolators

International use
UL / CSA approvals

5-year warranty

Warranty: 5 years
Defects occurring within 5 years from delivery date shall be remedied free of charge at our plant (carriage and insurance paid by sender).

■ **Product line**

Devices	Input	2 outputs	Order no.
VariTrans® A 20300 calibrated switching (both outputs simultaneously)	0 ... 20 mA, 4 ... 20 mA, 0 ... 10 V	0 ... 20 mA, 10 V 4 ... 20 mA, 10 V	A 20300 P0
DIN rail bus connector	Power supply routing for 2 A 20XXX P0 isolators each		ZU 0628

Power supply

24 V DC

VariTrans® A 20300

■ Specifications

Input data

Input	0 ... 20 mA, 4 ... 20 mA, 0 ... 10 V selectable (factory setting 0 ... 20 mA)
Input resistance	Current input: Voltage drop ≤ 0.1 V at 20 mA (approx. 350 mV during power failure) Voltage input: Approx. 100 kohms
Overload	Current input: Self-resetting overcurrent protection (PTC characteristic) Voltage input: Voltage limited to 30 V by suppressor diode, max. permitted permanent current 3 mA

Output data

Outputs 1 and 2	0 ... 20 mA, 4 ... 20 mA common selection (factory setting 0 ... 20 mA)
Load	≤ 10 V (≤ 500 ohms at 20 mA), ≤ 20 V (both outputs in series)
Offset	< 30 μ A
Residual ripple	< 10 mV _{rms} (at 500 ohm load)
Cut-off frequency	> 100 Hz

Transmission behavior

Gain error ¹⁾	< 0.2 % meas. val. with direct 1:1 current transmission < 0.3 % meas. val. with voltage input
Temperature influence ²⁾	< 0.01 %/K full scale (reference temperature 23 °C)

Power supply

Power supply	24 V DC (± 15 %), approx. 0.6 W Power supply can be routed from one device to another via cross-connections.
--------------	--

■ Specifications, continued

Isolation

Test voltage	1.5 kV~, 50 Hz: Power supply against input 2.5 kV~, 50 Hz: Outputs against each other and against input/power supply
Working voltage (basic insulation)	Up to 300 V AC/DC across all circuits with overvoltage category II and pollution degree 2. For applications with high working voltages, you should ensure there is sufficient spacing or isolation from neighboring devices and protection against electrical shocks.
Protection against electrical shock	Safe isolation according to EN 61140 by reinforced insulation according to EN 61010-1. Working voltage up to 300 V AC/DC across each output and all other circuits with overvoltage category II and pollution degree 2. For applications with high working voltages, you should ensure there is sufficient spacing or isolation from neighboring devices and protection against electrical shocks.

Standards and Approvals

EMC ³⁾	Product standard: EN 61326 Emitted interference: Class B Immunity to interference: Industry
Approvals	cURus, File No. E 220033, Standards: UL 508 and CAN/CSA 22.2 No. 14-95

Further data

Ambient temperature	Operation: 0 ... +55 °C when mounted in row Transport and storage: -25 ... +85 °C
Design	Modular housing with screw terminals, 6.2 mm wide, see dimension drawing
Protection class	IP 20
Mounting	For 35 mm top-hat rail to EN 60715
Weight	Approx. 50 g

1) Additional error in live-zero operation 20 µA

2) Average TC in specified operating temperature range 0 °C ... +55 °C

3) Slight deviations are possible during interference.

VariTrans® A 20300

■ Schematic diagram

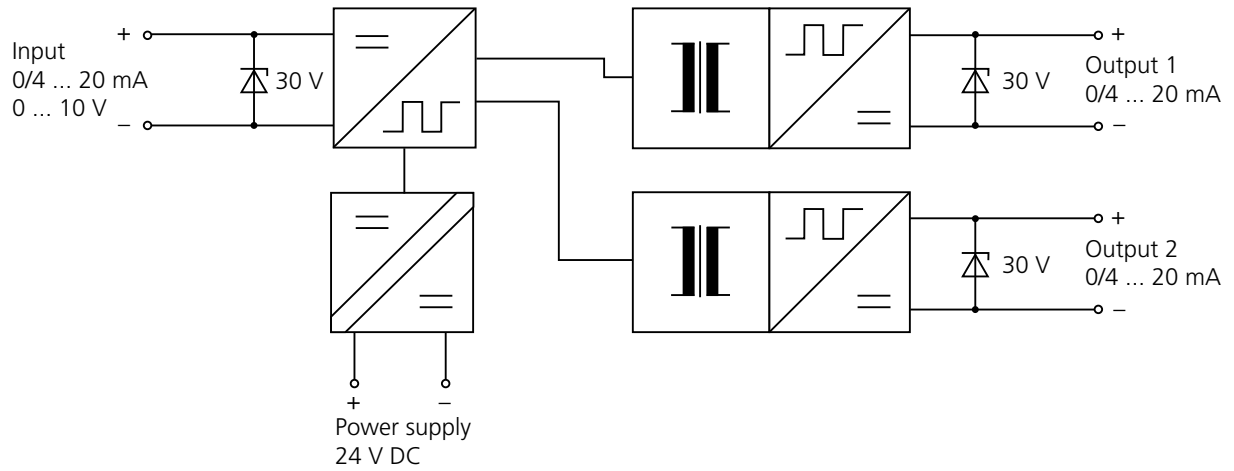

■ Typical applications

Signal doubling

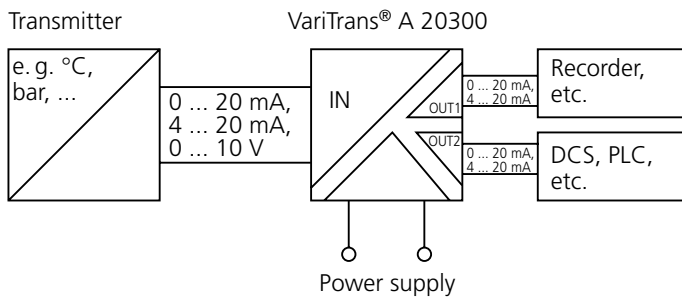

Load increase

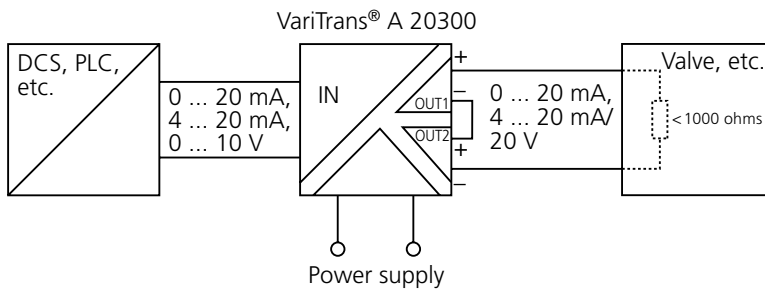

■ Dimension drawing and terminal assignments

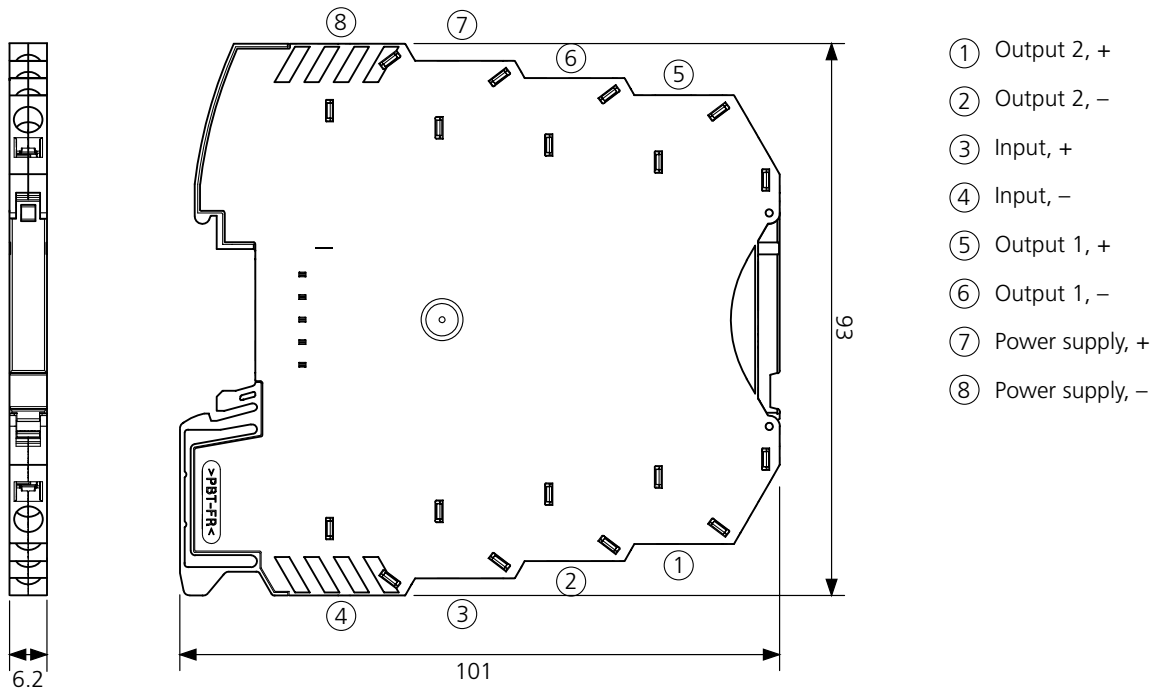

All dimensions in mm.

IsoTrans® A 20400



■ **The first reactionless passive isolator comprising the Bürdenstop® function to provide safe isolation of 0(4) ... 20 mA standard signals.**



The task

Measuring signals between sensor and controller should be isolated galvanically to ensure reliable and safe operation of the installation. Loop-powered standard-signal isolators provide a cost-favorable solution as there is no extra expenditure for power supply units and their wiring.

The problems

However, particularly in large installations, the lack of space for mounting the isolators and the increasing operating temperatures in distributors and switch cabinets can present a problem.

The solution

comes in the form of the Knick Advanced Series IsoTrans® A 20400 loop-powered isolators. An extremely high component density of up to 320 channels per meter top-hat rail and excellent technical properties, such as their safe isolation, make the isolators unbeatable – as does their price-performance ratio!

The housing

The ultra-slim 6 mm wide modular housing for one or two channels allows simple and fast assembly.

The function principle

The IsoTrans® A 20400 obtains its power directly from the measuring signal as a voltage drop without falsifying it. There are no costs for a power supply and wiring.

The IsoTrans® A 20400 has virtually no self-heating that would cause the electronic components to age faster. Together with a patented switching technique, this means maximum reliability. Due to this extraordinary long service life, we provide a 5-year warranty!

The technology

A transmission error of just 0.1 %, excellent square-wave response and very low residual ripple guarantee perfect signal transmission.

The low natural voltage requirement of approx. 1.7 V presents just a slight signal load.

The high test voltage up to 2.5 kV and safe isolation up to 300 V in accordance with EN 61140 protect operating personnel against, for example, the mains voltage.

Interference-free functionality

Now Knick has considerably expanded the application possibilities of passive isolators by implementing a Bürdenstop® (load stop) function. Here, the current supplied at the primary side is maintained independently from the output load. Thus, for the first time any excessive load increase at the output, such as caused by line breakage or inconstant loads including complex impedances, can be compensated for.

Warranty: 5 years

Defects occurring within 5 years from delivery date shall be remedied free of charge at our plant (carriage and insurance paid by sender).

The facts:

Extremely compact design
Up to 320 channels per meter

1 and 2-channel versions
Cheap and flexible for a wide range of applications

Galvanic isolation between input and output
Protection against incorrect measurements or damage to the equipment due to parasitic voltages

Safe electrical isolation
up to 300 V AC/DC according to EN 61140 to protect personnel and equipment

Bürdenstop® prevents undesired feedback
e. g. in the case of an open output circuit

No power supply required
Cost savings due to lower wiring requirement, no mains influences, no unnecessary heating and therefore maximum service life of components

High accuracy
No falsification of measuring signal

Maximum reliability
No repair and failure costs

International use
UL / CSA approvals

5-year warranty

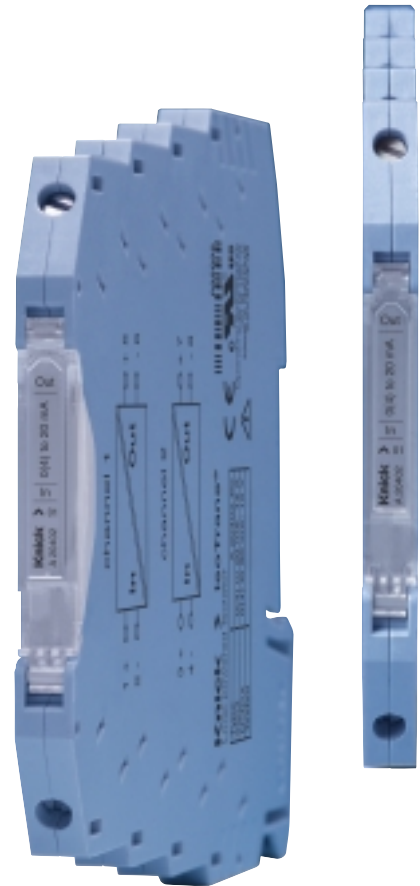

■ Product line

Devices	Input	Order no.
IsoTrans® A 20400	1-channel, P0 modular housing (6 mm wide)	A 20401 P0
	2-channel, P0 modular housing (6 mm wide)	A 20402 P0
	1-channel, P0 modular housing (6 mm wide), with Bürdenstop®	A 20411 P0
	2-channel, P0 modular housing (6 mm wide), with Bürdenstop®	A 20412 P0

Power supply

None, supply from input signal

IsoTrans® A 20400

■ Specifications

Input data

	A 20401 and A 20402 (without Bürdenstop®)	A 20411 and A 20412 (with Bürdenstop®)
Input	0 (4) ... 20 mA / max. 18 V	0 (4) ... 20 mA / max. 3 V
Operating current	<150 μ A	
Voltage drop	Approx. 1.7 V at 20 mA	Approx. 1.7 V at 20 mA
Overload	40 mA, 18 V	50 mA, 3 V

Output data

Output	0(4) ... 20 mA / max. 12 V (600 ohm load at 20 mA)	0(4) ... 20 mA / max. 1.2 V (60 ohm load at 20 mA)
Residual ripple	<10 mV _{rms}	<10 mV _{rms}

Transmission behavior

Transmission error	<0.1 % full scale	<0.1 % full scale
Load error	<0.05 % meas. val. / 100 ohm	Negligible
Response time (T ₉₉)	Approx. 5 ms at 500 ohm load	Approx. 0.5 ms at 60 ohm load
Temperature influence ¹⁾	<0.002 %/K meas. val. per 100 ohm load (reference temperature 23 °C)	<0.002 %/K meas. val. (reference temperature 23 °C)

Isolation

Test voltage	2.5 kV AC
Protection against electrical shock	Safe isolation according to EN 61140 by reinforced insulation according to EN 61010-1. Working voltage up to 300 V AC/DC across input and output of the same channel and across the channels themselves with overvoltage category II and pollution degree 2. For applications with high working voltages, you should ensure there is sufficient spacing or isolation from neighboring devices and protection against electrical shocks.

■ Specifications, continued

Standards and Approvals

EMC ²⁾	Product standard: EN 61326 Emitted interference: Class B Immunity to interference: Industry
Approvals	cURus, File No. E 220033, Standards: UL 508 and CAN/CSA 22.2 No. 14-95

Further data

Chopper frequency	Approx. 100 kHz
Ambient temperature	Operation: -20 ... +65 °C Transport and storage: -25 ... +85 °C
Design	Modular housing with screw terminals, 6.2 mm wide, see dimension drawing
Protection class	IP 20
Mounting	For 35 mm top-hat rail to EN 50022
Weight	Approx. 50 g

1) Average TC in specified operating temperature range -20 ... +65 °C

2) Applies to 4 ... 20 mA, slight deviations are possible during interference

IsoTrans® A 20400

■ Schematic diagram

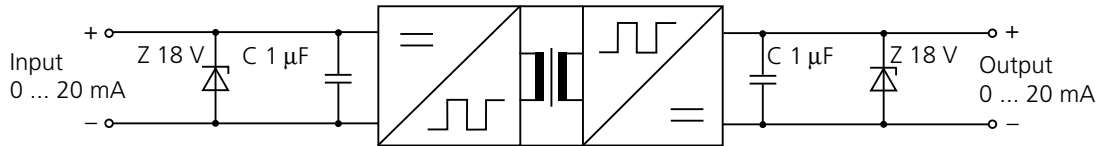

■ Typical application

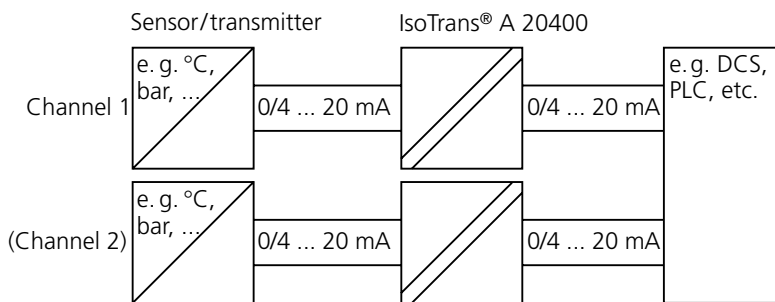

■ Transfer function with Bürdenstop® (loadstop)

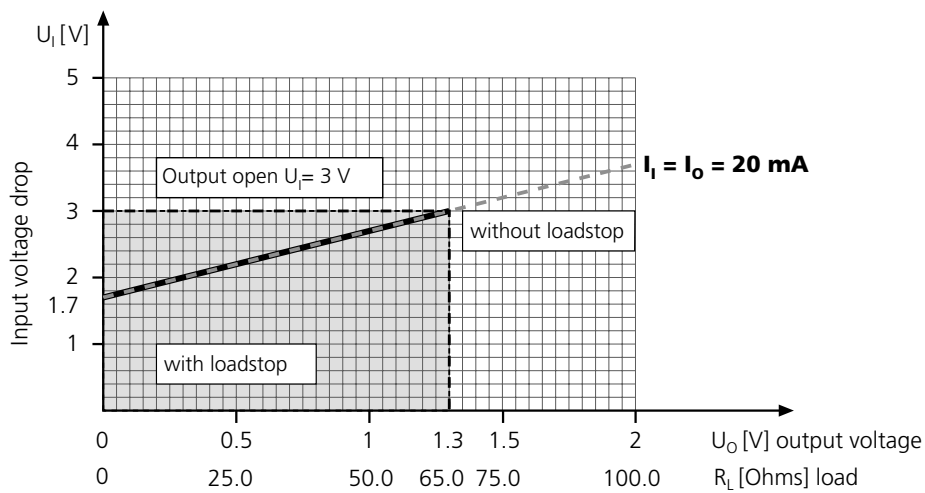

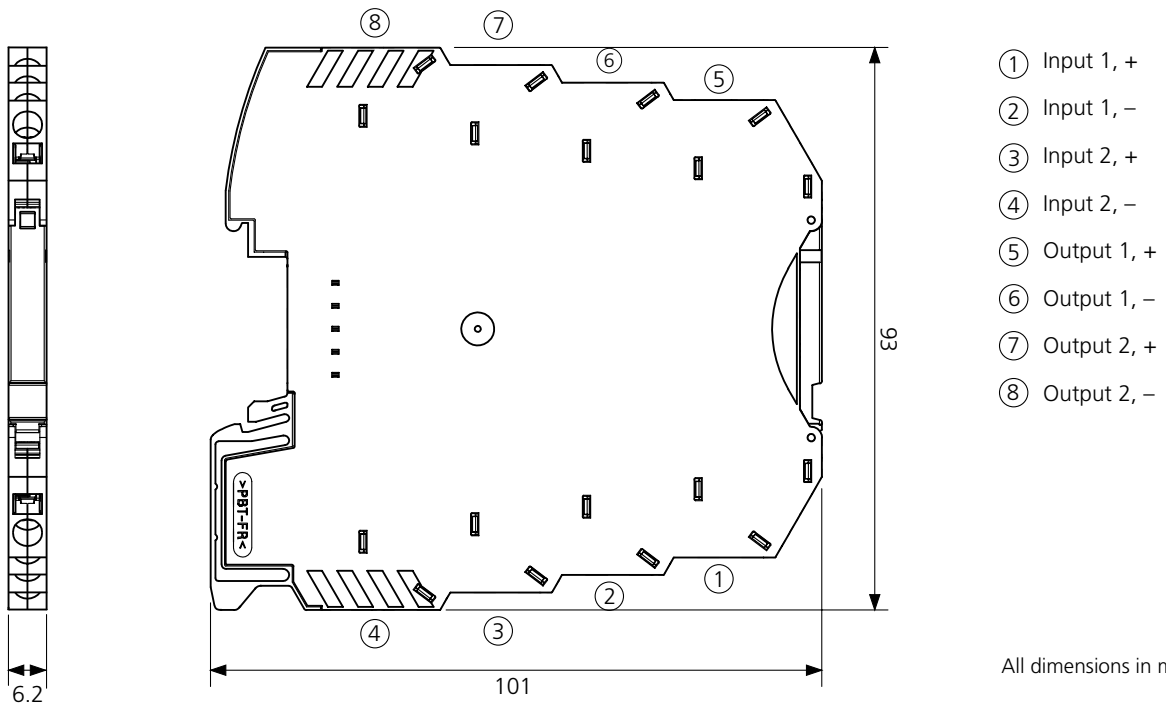
Knick >**■ Dimension drawing and terminal assignments**

IsoAmp® PWR A 20100

Knick >

■ **Repeater power supply in a 6 mm housing with calibrated switching of output signals, HART transmission, and safe electrical isolation**

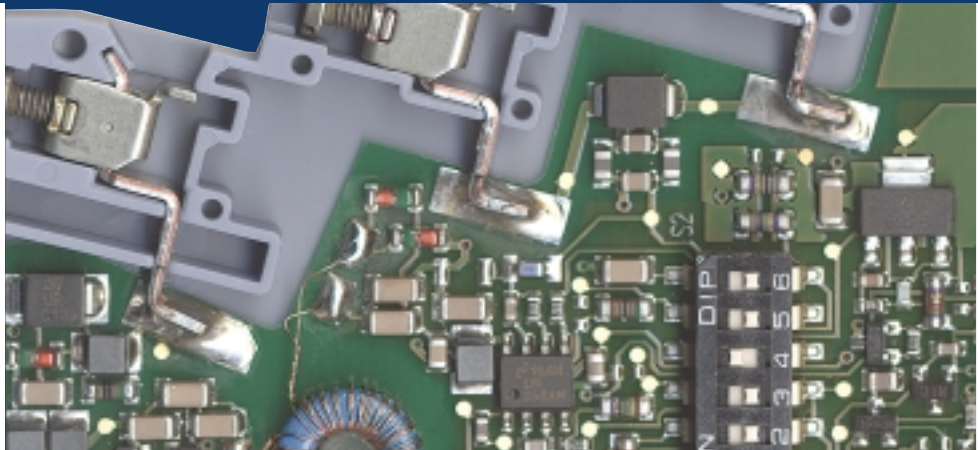

The task

Flexible and safe supply of 2-wire transmitters via the 4 ... 20 mA current loops with simultaneous transmission of data protocols for SMART transmitters / HART communication. Conversion of output signals in 0 ... 20 mA or 0 .. 10 V, if required.

The problems

Good isolator properties combined with high transmission accuracy often result in complex systems that cost space and money.

Galvanic isolation of the supply and signal processing, however, are frequently indispensable to exclude measuring problems from the start. Therefore, the selection of possible alternatives within the budget is often limited.

The solution

Knick is the first manufacturer to provide a repeater power supply for 2-wire transmitters in an extremely compact 6 mm housing.

The IsoAmp® PWR A 20100 supplies the transmitter with power and transmits the measuring signal galvanically isolated to the output with a high level of accuracy. In case a signal other than the 4 to 20 mA current loop

signal is required, the repeater power supply provides a selection of output signals via DIP switches. HART signals are of course transmitted without alteration. Its width of just 6 mm also allows use of the repeater power supply in the tightest of spaces.

The housing

Mounted in a tried and tested 6.1 mm wide modular housing with screw terminals. The outputs are selected using DIP switches that can be accessed without opening the housing.

The advantages

The new IsoAmp® PWR A 20100 repeater power supply combines small dimensions with excellent features! Safe isolation and 0.1% accuracy also allow use for applications with increased requirements.

The technology

The output signal is switchable between 0 ... 20 mA, 4 ... 20 mA, and 0 ... 10 V. The calibrated measuring ranges are selected via DIP switches.

In addition to the analog signal, the repeater power supply transmits data protocols for SMART transmitters (according to the HART specification).

It allows bi-directional communication with the field device via a host computer or HART communicator (hand-held communicator).

The facts:

Extremely flat

3-port isolation in a 6 mm modular housing

Flexible and highly accurate

Calibrated output signal switching

Quick and easy configuration

Range selection using lateral DIP switches – easy to access, yet protected against accidental adjustment

Low-cost assembly

Supply of the current loop and galvanic isolation of the measured signal in one device

Safe electrical isolation

up to 300 V according to EN 61140

SMART transmitter

(to HART specification)

Cross-connection combs for power supply

Power supply only wired once for almost any number of parallel repeater power supplies

5-year warranty

■ **Product line**

Devices	Input	Output	Order no.
IsoAmp® PWR A 20100	4 ... 20 mA	4 ... 20 mA 0 ... 20 mA 0 ... 10 V calibrated selection	A 20100 F0
Cross-connections	Pluggable cross-connection for looping through of power supply for up to 41 power supply connections of B 10XXX F0 and A 20XXX F0		ZU 0542
Power supply	24 V DC		

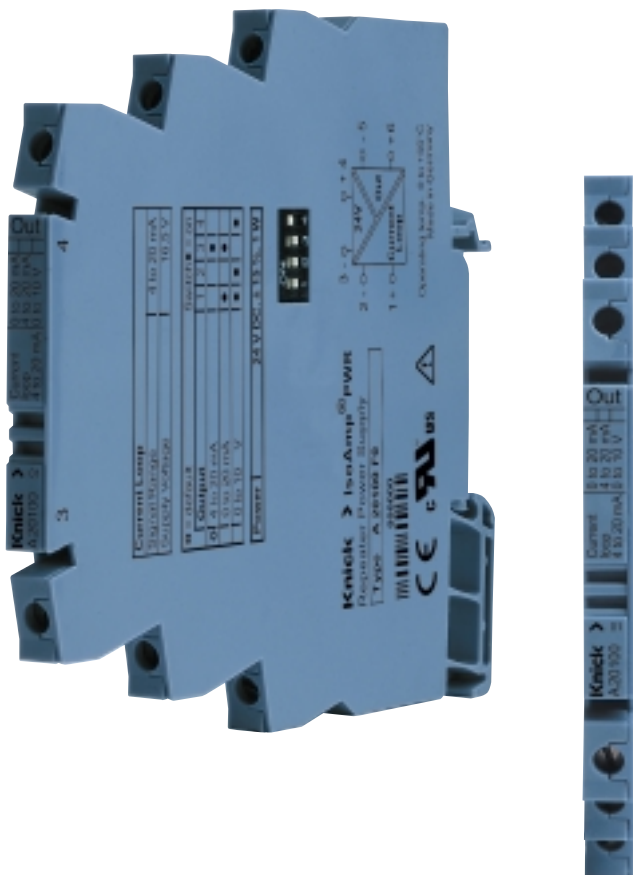

Warranty: 5 years
 Defects occurring within 5 years from delivery date shall be remedied free of charge at our plant (carriage and insurance paid by sender).

IsoAmp® PWR A 20100

■ Specifications

Input data

Input (current loop)	4 ... 20 mA, 16.5 V supply voltage, constant for 3 ... 22 mA, current limited to max. 25 mA
Residual ripple	<10 mV _{rms}

Output data

Output	4 ... 20 mA, 0 ... 20 mA or 0 ... 10 V, calibrated selection
Output signal with input short-circuit	22 ... 25 mA or 11 ... 12.5 V
Output signal with open input	<3 mA or 0 for 0 ... 20 mA or 0 ... 10 V outputs
Load with output current with output voltage	≤10 V (≤500 ohms at 20 mA) ≤1 mA (≥10 kohms at 10 V)
Offset Current output ¹⁾ Voltage output	<30 μA <30 mV
Residual ripple at output	<10 mV _{rms}

Transmission behavior

Gain error Current output Voltage output	<0.1 % meas. val. <0.2 % meas. val.
Response time	<2 ms
Communication ²⁾ (4 ... 20 mA output)	Bidirectional transmission of FSK signals between output and current loop according to HART specification

Power supply

Power supply	24 V DC (±15 %), approx. 1 W The power supply can be routed from one device to another via cross-connections.
--------------	--

■ Specifications, continued

Isolation

Galvanic isolation	3-port isolation between current loop, output, and power supply
Test voltage	2.5 kV AC current loop against output/power supply 510 V AC output against power supply
Working voltage (basic insulation)	Up to 600 V AC/DC across current loop and output/power supply with overvoltage category II and pollution degree 2, up to 100 V AC/DC across output and power supply with category II und degree 2 according to EN 61010-1. For applications with high working voltages, you should ensure there is sufficient spacing or isolation from neighboring devices and protection against electrical shocks.

Standards and Approvals

Protection against electrical shock	Safe isolation according to EN 61140 by reinforced insulation according to EN 61010-1. Up to 300 V across current loop and output/power supply with overvoltage category II and pollution degree 2. For applications with high working voltages, you should ensure there is sufficient spacing or isolation from neighboring devices and protection against electrical shocks.
EMC ²⁾	Product standard: EN 61326 Emitted interference: Class B Immunity to interference: Industry
Approvals	cURus, File No. E 220033, Standards: UL 508 and CAN/CSA 22.2 No. 14-95

Further data

Ambient temperature	Operation: 0 ... +55 °C Transport and storage: -25 ... +85 °C
Design	Modular housing with screw terminals, 6.1 mm wide, see dimension drawing
Protection class	IP 20
Mounting	For 35 mm top-hat rail to EN 50022 See dimension drawing for conductor cross-section
Weight	Approx. 50 g

1) Additional error 30 µA for 0 ... 20 mA output
2) Slight deviations are possible during interference

IsoAmp® PWR A 20100

■ Schematic diagram

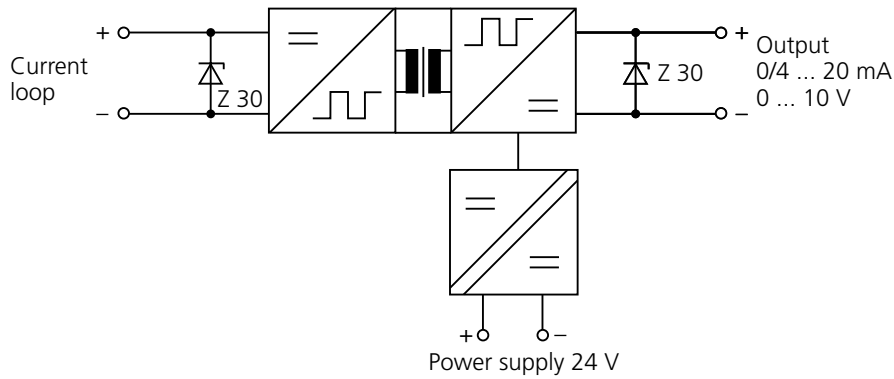

■ Typical application

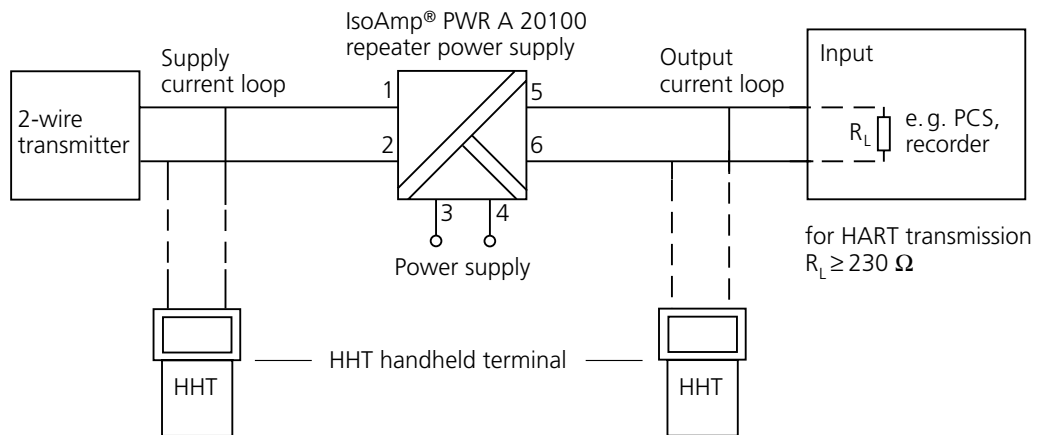

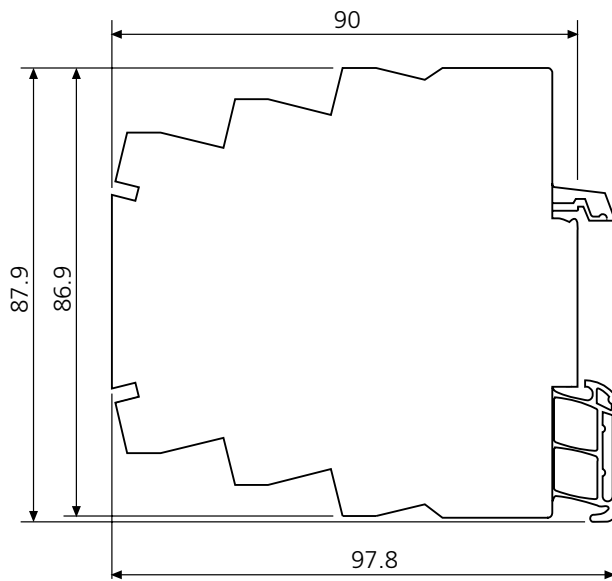
Knick >**■ Dimension drawing and terminal assignments**

All dimensions in mm.

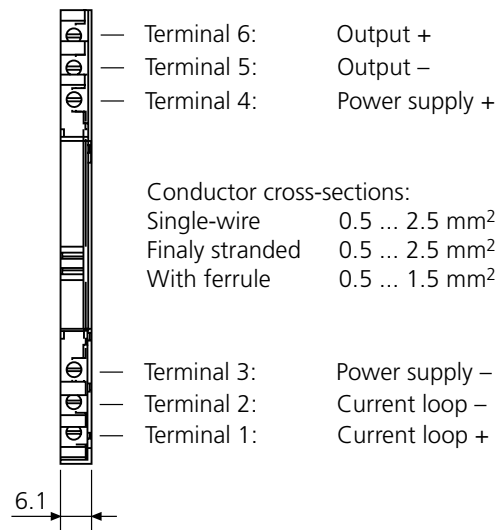

IsoAmp® PWR B 10116



■ Repeater power supply in 6 mm housing

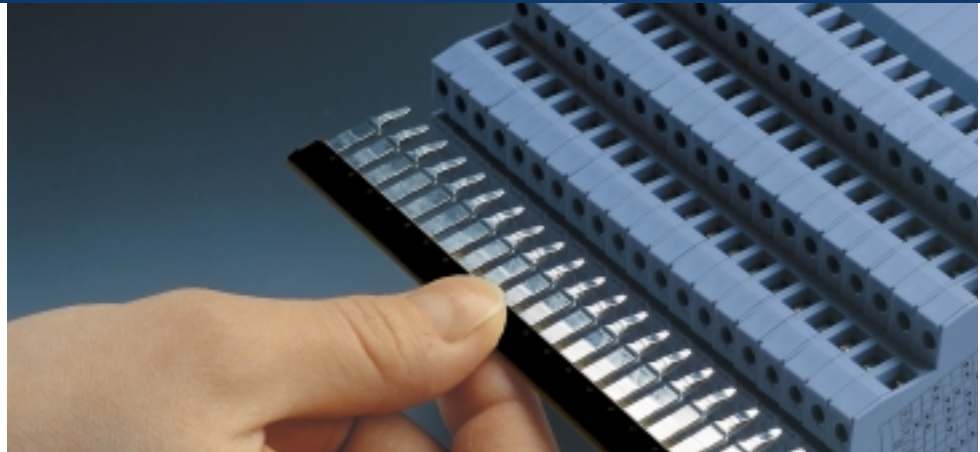

The task

Supply of 2-wire transmitters via the measuring line and 1:1 transmission of 4 ... 20 mA measuring signals.

The problems

In many cases, space is limited at the operating site and furthermore, additional effort for the supply units and galvanic isolation often requires two separate devices.

The solution

We supply one of the narrowest repeater power supplies at an extremely attractive price. The IsoAmp® PWR B 10116 supplies the transmitter with power and transmits the measuring signal galvanically isolated to the output with a high level of accuracy. A high supply voltage allows use with almost all commercially available 2-wire transmitters.

The housing

Mounted in a 6-pin terminal block housing with 6.1 mm row width. Connection with screw terminals.

The advantages

The new IsoAmp® PWR B 10116 repeater power supply unites excellent technology with unbeatable value for money.

The technology

Transformer signal and energy transmission. The output signal is permanently set to 4 ... 20 mA.

The facts:

Extremely flat

3-port isolation in a 6 mm modular housing

Low-cost assembly

Supply of the current loop and galvanic isolation of the measured signal in one device

Safety in the smallest space

3-port isolation in a 6 mm housing

Supplies all common 2-wire transmitters (2-wire sensors)

Power supply 24 V DC

Cross-connection combs for power supply

Power supply only wired once for almost any number of parallel repeater power supplies

5-year warranty



■ **Product line**

Devices	Input	Output	Order no.
IsoAmp® PWR B 10116	4 ... 20 mA	4 ... 20 mA	B 10116 F0
Cross-connections	Pluggable cross-connection for looping through of power supply for up to 41 power supply connections of B 10XXX F0 and A 20XXX F0		ZU 0542
Power supply	24 V DC		

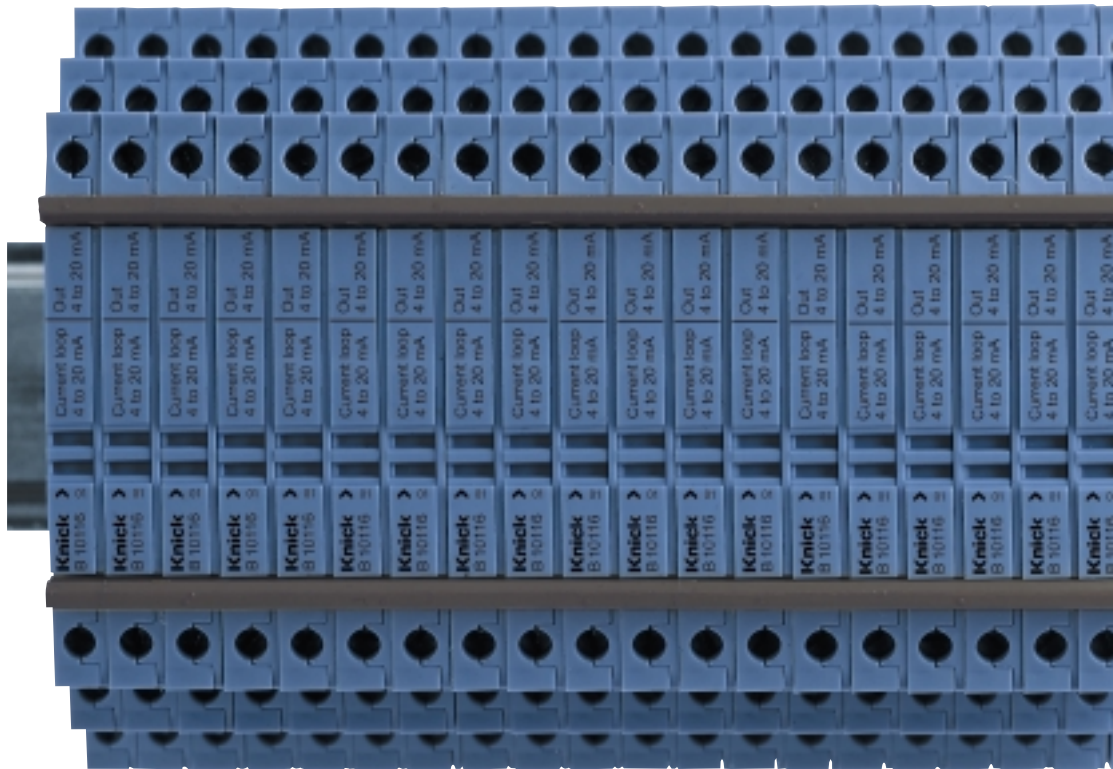

Warranty: 5 years
 Defects occurring within 5 years from delivery are remedied free of charge at our plant (carriage and insurance paid by sender).

IsoAmp® PWR B 10116

■ Specifications

Input data

Input (Current loop)	4 ... 20 mA, 16.5 V supply voltage, constant for 3 ... 22 mA, current limited to max. 25 mA
Residual ripple	<10 mV _{rms}

Output data

Output	4 ... 20 mA
Output signal with input short-circuit	22 ... 25 mA
Output signal with open input	<3 mA
Load	≤10 V (500 ohms at 20 mA)
Offset	<30 μA
Residual ripple at output	<10 mV _{rms}

Transmission behavior

Gain error	<0.1 % meas. val.
Response time	<5 ms

Power supply

Power supply	24 V DC (±15 %), approx. 1 W The power supply can be routed from one device to another via cross-connections.
--------------	--

■ Specifications, continued

Isolation

Galvanic isolation	3-port isolation between current loop, output, and power supply
Test voltage	1.5 kV AC current loop against output/power supply 510 V AC output against power supply
Working voltage (basic insulation)	Up to 300 V AC/DC across current loop and output/power supply with overvoltage category II and pollution degree 2, up to 100 V AC/DC across output and power supply with category II und degree 2 according to EN 61010-1. For applications with high working voltages, you should ensure there is sufficient spacing or isolation from neighboring devices and protection against electrical shocks.

Standards and Approvals

EMC ¹⁾	Product standard: EN 61326 Emitted interference: Class B Immunity to interference: Industry
Approvals	cURus, File No. E 220033, Standards: UL 508 and CAN/CSA 22.2 No. 14-95

Further data

Ambient temperature	Operation: 0 ... +55 °C Transport and storage: -25 ... +85 °C
Design	Modular housing with screw terminals, 6.1 mm wide, see dimension drawing
Protection class	IP 20
Mounting	For 35 mm top-hat rail to EN 50022 See dimension drawing for conductor cross-section
Weight	Approx. 50 g

1) Additional error 30 µA for 0 ... 20 mA output

IsoAmp® PWR B 10116

■ Schematic diagram

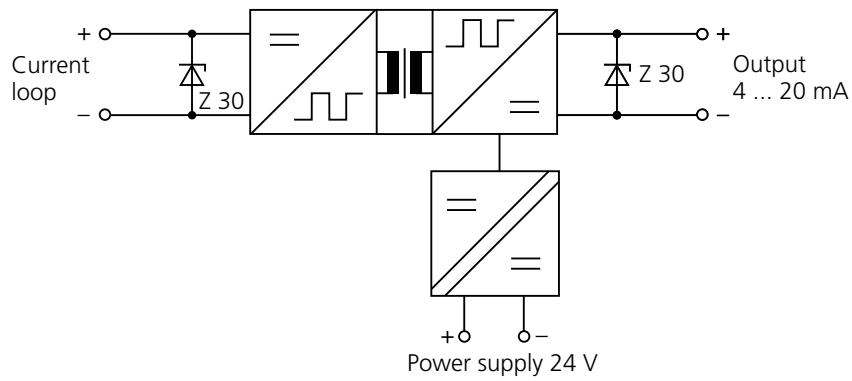

■ Typical application

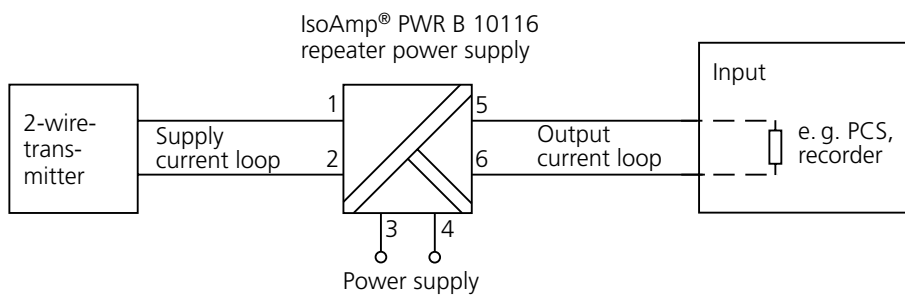

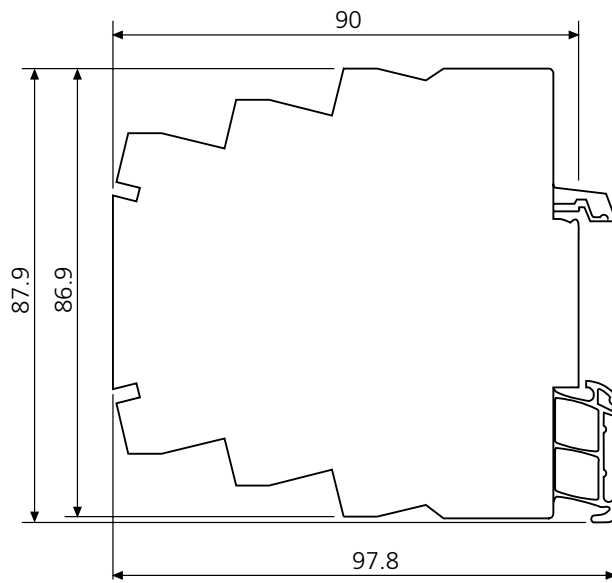
Knick **■ Dimension drawing and terminal assignment**

All dimensions in mm.

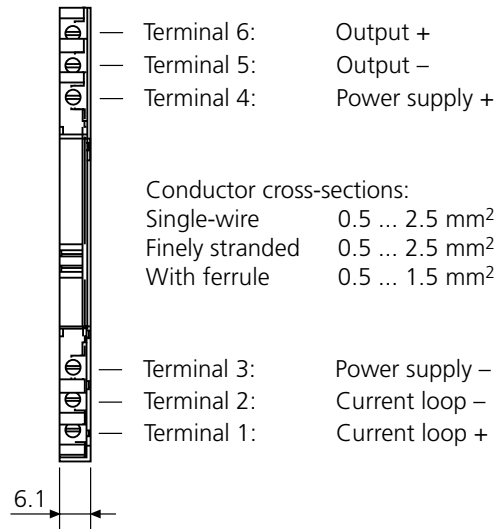

Isolation Amplifiers
Transmitters

Indicators

Process Analyzers

Portable Meters

Laboratory Meters

Sensors

Fittings



**Knick Elektronische Messgeräte
GmbH & Co. KG**

Beuckestraße 22, 14163 Berlin, Germany
Phone: +49 (0)30-801 91-0
Telefax: +49 (0)30-801 91-200
knick@knick.de · www.knick.de