

Modular Housings

Knick >

IsoTrans® 600



For isolation and conversion of sinusoidal alternating currents and voltages into standard signals.

The Task

For monitoring mains supplies, control of electric motors etc., alternating currents up to 10 A and voltages up to 800 V are converted to 0(4) ... 20 mA or 0 ... 10 V standard signals.

The Problem

is the provision of several AC/DC transmitters for different measurement ranges. Furthermore the maintenance staff and the system need to be protected against high potentials.

The Solution

comes with the switchable loop-powered IsoTrans® 600 AC/DC transmitters.

Only the transmitters with 4 ... 20 mA output require 230 V AC power supply.

The calibrated range selection for all regular alternating voltages and the 22.5 mm slim modular housing allow universal use.



The Advantages

The accuracy class is 0.5 – no need to readjust the switchable ranges.

The IsoTrans® 600 provides Safe Isolation up to 600 V AC/DC according to EN 61010-1.

This allows use in 3-phase systems. Further measures for ensuring safe isolation are not necessary.

Except for the 4 ... 20 mA output, the IsoTrans® 600 is supplied directly from the measurement signal. There are no costs for a power supply and wiring.

Optimized switching technology makes the power consumption and the resulting self-heating very low. This protects against unnecessary temperature-related component aging and thus increases reliability.

The Technology

For conversion, the average input values are calibrated to form r. m. s values.

Short rise times, very low residual ripple and excellent overload behavior guarantee maximum transmission quality.

AC/DC Transmitters

Isolation Amplifiers
Transmitters

Indicators

Process Analytics

Portable Meters

Laboratory Meters

Sensors

Fittings

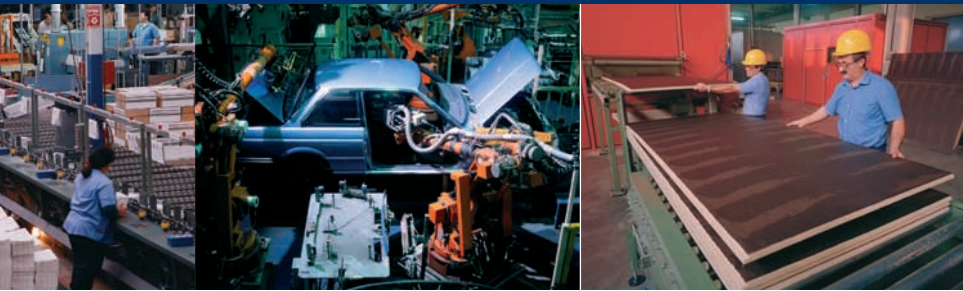

Knick >

■ The Facts

Calibrated range selection

Simple stockkeeping due to universal application possibilities, no need for complicated readjustment

Loop-powered models with 0 ...20 mA and 0 ... 10 V output

Reduced wiring effort, no mains influences

Safe Isolation according to EN 61140

Protection of maintenance staff and subsequent devices against non-permitted high voltages

Modular 22.5 mm housing

Low space requirement due to compact design

High long-term stability and accuracy

Reliable operation without recalibration

Very low power consumption

allows minimum ratings of the upstream current and voltage transformer

Very low self-heating

No temperature-related component aging, high MTBF

Maximum reliability

No repair and failure costs

High reliability

5-year warranty

Warranty
5 years!

Defects occurring within 5 years from delivery are remedied free of charge at our works (carriage and insurance paid by sender).

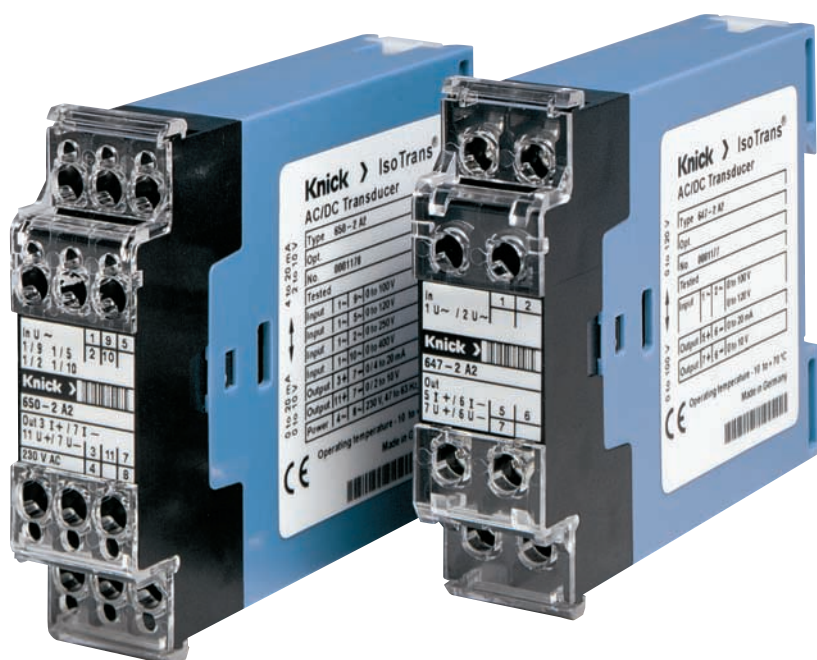

Modular Housings

IsoTrans® 600

■ Product Line

Devices

IsoTrans® 600

with current input

	Input	Output	Order No.
IsoTrans® 611-1	0 ... 1 A	0 ... 20 mA	611-1 A2
IsoTrans® 621-1 (with power supply)	0 ... 1 A	4 ... 20 mA	621-1 A2
IsoTrans® 631-1	0 ... 1 A	0 ... 10 V	631-1 A2
IsoTrans® 615-1	0 ... 5 A	0 ... 20 mA	615-1 A2
IsoTrans® 625-1 (with power supply)	0 ... 5 A	4 ... 20 mA	625-1 A2
IsoTrans® 635-1	0 ... 5 A	0 ... 10 V	635-1 A2

IsoTrans® 600

with voltage input

IsoTrans® 647-2	0 ... 100/120 V switch selectable	0 ... 20 mA / 0 ... 10 V terminal selectable	647-2 A2
IsoTrans® 648-2	0 ... 250/400 V switch selectable	0 ... 20 mA / 0 ... 10 V terminal selectable	648-2 A2
IsoTrans® 650-2 (with power supply)	0 ... 100 / 120 / 250 / 400 V, terminal selectable	0 ... 20 mA / 4 ... 20 mA 0 ... 10 V, switch/terminal selectable	650-2 A2

Power supply

621-1, 625-1, 650-2: 230 V AC, others: none, supply from input signal

Options

IsoTrans® 635-1 and IsoTrans® 650-2 for input frequency 16 2/3 Hz
(635-1: response time 1 s, load ≥ 7.5 kohms)

469

■ Selection Aid

Input		Output		
		0 ... 20 mA	4 ... 20 mA	0 ... 10 V
0 ... 1 A AC		611-1 A2	621-1 A2*)	631-1 A2
		615-1 A2	625-1 A2*)	635-1 A2
0 ... 5 A AC		647-2 A2	650-2 A2*)	647-2 A2
		650-2 A2*)		650-2 A2*)
0 ... 100 V AC		647-2 A2	650-2 A2*)	647-2 A2
		650-2 A2*)		650-2 A2*)
0 ... 120 V AC		648-2 A2	650-2 A2*)	648-2 A2
		650-2 A2*)		650-2 A2*)
0 ... 250 V AC		648-2 A2	650-2 A2*)	648-2 A2
		650-2 A2*)		650-2 A2*)
0 ... 400 V AC		648-2 A2	650-2 A2*)	648-2 A2
		650-2 A2*)		650-2 A2*)

*) With power supply

■ Specifications

Input data	IsoTrans® 600 with current input			IsoTrans® 600 with voltage input		
	6x1	6x5		647	648	650
Input ¹⁾	0 ... 1 A	0 ... 5 A		0 ... 100 / 120 V	0 ... 250 / 400 V	0 ... 100 / 120 / 250/400 V
	48 ... 63 Hz	48 ... 63 Hz		switch selectable Measurement from 10 % full scale 48 ... 63 Hz	switch selectable Measurement from 10 % full scale 48 ... 63 Hz	terminal selectable 48 ... 63 Hz
Overload	Continuous: 2 times I_{nom} 1 s: 50 times I_{nom}			Continuous: 1.5 times V_{nom} 1 s: 4 times V_{nom}		
Input power	Approx. 1 VA			max. 0.4 VA		
Output data	IsoTrans® 600 with current input			IsoTrans® 600 with voltage input		
	61x	62x	63x	647	648	650
Output	0 ... 20 mA	4 ... 20 mA	0 ... 10 V	0 ... 20 mA/ 0 ... 10 V		0(4) ... 20 mA/ 0(2) ... 10 V
Load	≤ 750 ohms		≥ 2 kohms	with output current: ≤ 600 ohms with output current: ≥ 1 kohm		
Response time (T_{90})	Approx. 0.1 s		<0.2 s	Approx. 0.25 s		
Load 0 ohm	Approx. 0.1 s					
Load 750 ohms	Approx. 0.2 sec					
Transmission behavior						
Transmission error	Class 0.5 (EN 60688)					
Power supply						
Power supply (models with 4 ... 20 mA output)	230 V AC $-15\% +10\%$, 47 ... 63 Hz, approx. 1 VA (IsoTrans® 650 approx. 1.5 VA)					
Isolation						
Galvanic isolation	With power supply:		3-port isolation between input, output and power supply			
	Loop-powered:		Isolation between input and output			
Test voltage	With current input:		6 kV AC for models with power supply: 6 kV AC (input against output/ power supply), 4 kV AC (output against power supply)			
	With voltage input:		4 kV AC			

1) Other input values up to 10 A or 800 V in the frequency range 16 ... 63 Hz are available on request

Modular Housings

IsoTrans® 600

Specifications (continued)

Isolation (continued)

Protection against electric shock

Safe Isolation according to EN 61140 by reinforced insulation in accordance with EN 61010-1. Working voltages with overvoltage category II and pollution degree 2: up to 400 V AC/DC across output and power supply, up to 600 V AC/DC across input and output and, where necessary, power supply (current isolator up to category III, degree 2). For applications with high working voltages, you should ensure there is sufficient spacing or isolation from neighboring devices and protection against electric shocks.

Standards and approvals

Surge withstand

5 kV, 1.2/50 μ s, according to IEC 255-4

EMC

89/336/EEC directive; EN 61326

Other data

Ambient temperature

Operation: $-10 \dots +70 \text{ }^\circ\text{C}$
Transport and storage: $-30 \dots +80 \text{ }^\circ\text{C}$

Design

A7 modular housing, width 22.5 mm, screw terminals
See dimension drawings for further measurements

Ingress protection

Housing IP 40, terminals IP 20

Mounting

With snap-on mounting for 35 mm top hat rail according to EN 50022 or M4 screw mounting, see dimension drawings for conductor cross section

Weight

6xx-1: Approx. 350 g
6xx-2: Approx. 250 g

■ Block Diagrams

AC/DC Transmitter with Current Input

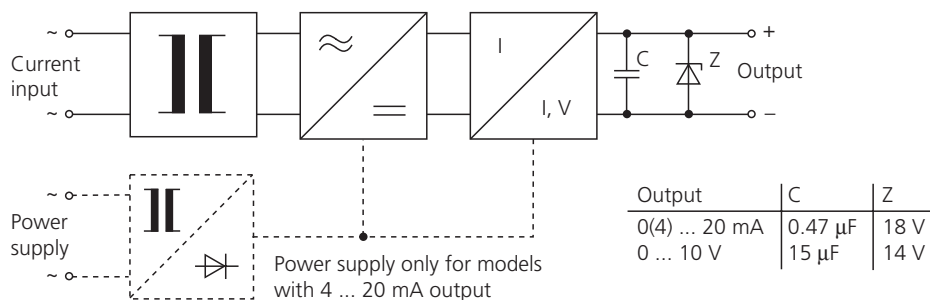

Block Diagrams (continued)

AC/DC Transmitter with Voltage Input

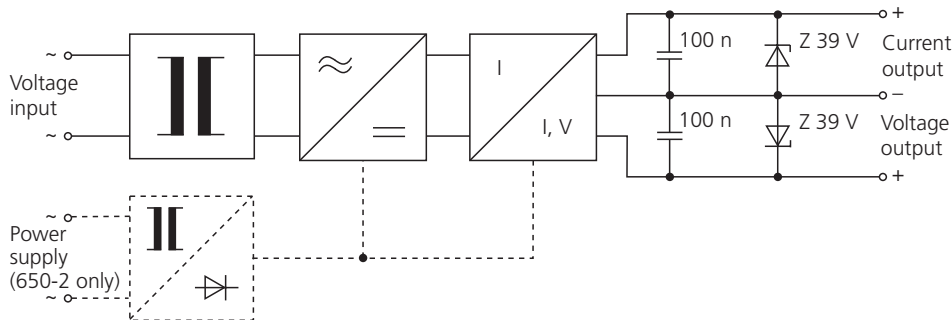

■ Dimension Drawings and Terminal Assignments

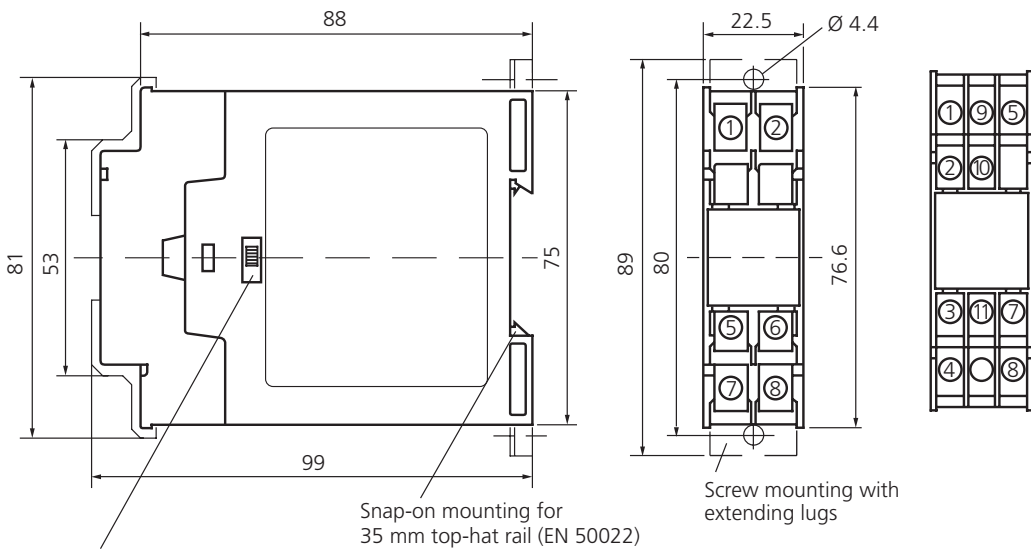

Range switch, do not use during operation!

M2.5x8 connecting screws
with self-releasing clamping pieces
max. conductor cross-section
2x2.5 mm² solid or
2x1.5 mm² stranded wire with ferrule

AC/DC Transmitters with Current Input 6**-1

- 1 Input ~
 - 2 Input ~
 - 5 Output +
 - 6 Output -
 - 7 Power supply ~ }
 - 8 Power supply ~ }
- (only for Models 621 and 625,
otherwise not connected)

AC/DC Transmitters with Voltage Input 647-2 and 648-2

- 1 Input ~
- 2 Input ~
- 5 Output + 20 mA
- 6 Output -
- 7 Output + 10 V

AC/DC Transmitters with Voltage Input 650-2

- 1 Input 0
- 9 Input 100 V ~
- 5 Input 120 V ~
- 2 Input 250 V ~
- 10 Input 400 V ~
- 7 Output -
- 11 Output + 20 mA
- 3 Output + 10 V
- 4 Power supply ~
- 8 Power supply ~

All dimensions in mm!