

# Resilient Seated Solid Wedge Gate Valve With Bevel Gear Operator - Series 6700

AWWA C509 & C515 ▪ OS&Y Type ▪ FL x FL ▪ Sizes 18" - 24"

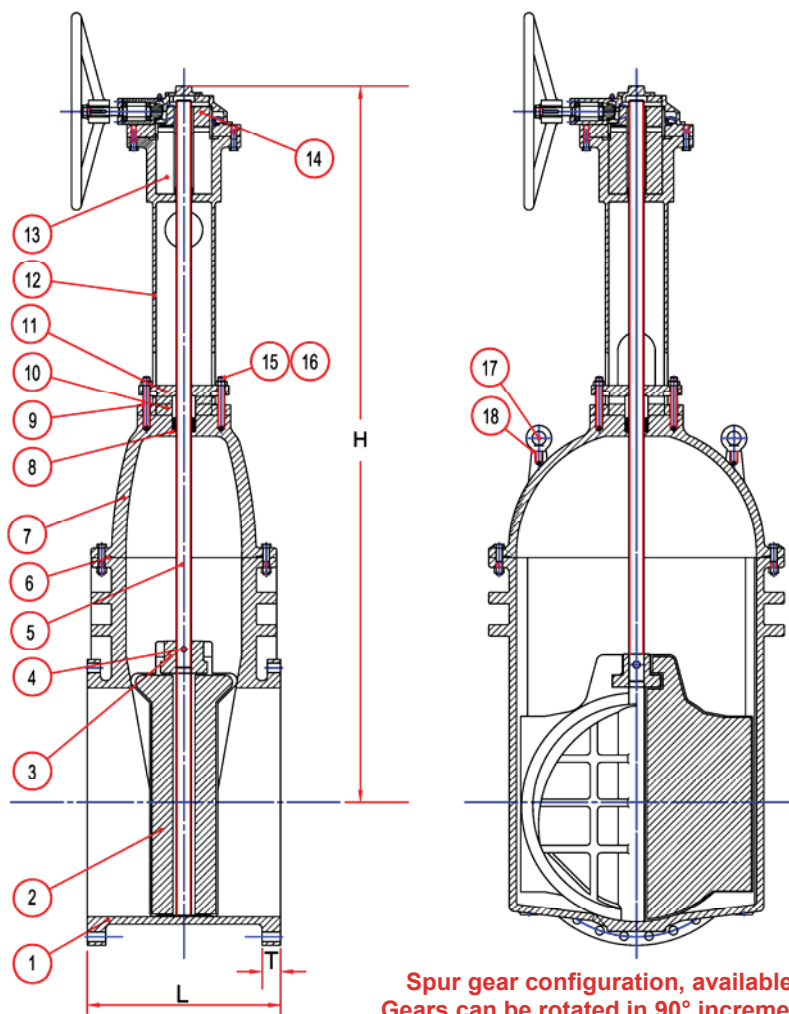

No.	Part Name	Materials
1	Body	Ductile Iron ASTM A536 65-45-12
2	Wedge	Ductile Iron EPDM Encapsulated
3	Stem Nut	Stainless Steel
4	Stem Pin	Stainless Steel
5	Stem	Stainless Steel, Bronze Available
6	O-Ring Gasket	EPDM
7	Bonnet	Ductile Iron ASTM A536 65-45-12
8	Packing	Graphite Non Asbestos
9	Bolt	Stainless Steel
10	Gland	Brass ASTM B16
11	Gland Follower	Ductile Iron ASTM A536 65-45-12
12	Yoke	Ductile Iron ASTM A536 65-45-12
13	Stem Nut	Bronze
14	Bevel Gear	Carbon Steel AISI 1045
15	Bolt	Stainless Steel
16	Nut	Stainless Steel
17	Eye Bolt	Carbon Steel, Zinc Plated
18	Washer	Stainless Steel

## Features:

- Design and Materials Exceed AWWA C509, C515 & C550.
- Flanges Conform to ANSI B16.1, Class 125.
- C509 Thick Wall Ductile Iron, Body, Bonnet, and Gland.
- Fusion Bonded Epoxy Coatings In and Out per AWWA C550.
- Stainless Steel Nuts, Bolts, and Washers.
- Stainless Steel Stem, Bronze Available.
- Ductile Iron, EPDM Encapsulated Wedge.
- EPDM Gaskets and O-Rings.
- Available with Bypass.
- Handwheel Operator, 2" AWWA Ductile Iron Nut, or Automatic Actuator Available.

## Dimensions:

Size	Model	L	H	T	Approx. Weight
18"	6718	17"	66"	1 <sup>5</sup> / <sub>8</sub> "	1,430#
20"	6720	18"	76 <sup>1</sup> / <sub>2</sub> "	1 <sup>3</sup> / <sub>4</sub> "	1,970#
24"	6724	20"	86 <sup>1</sup> / <sub>2</sub> "	1 <sup>7</sup> / <sub>8</sub> "	2,990#