

Resilient Seated Solid Wedge Gate Valve - Series 6400

AWWA C509 & C515 ▪ NRS Type ▪ FL x PO ▪ Sizes 4" - 12"

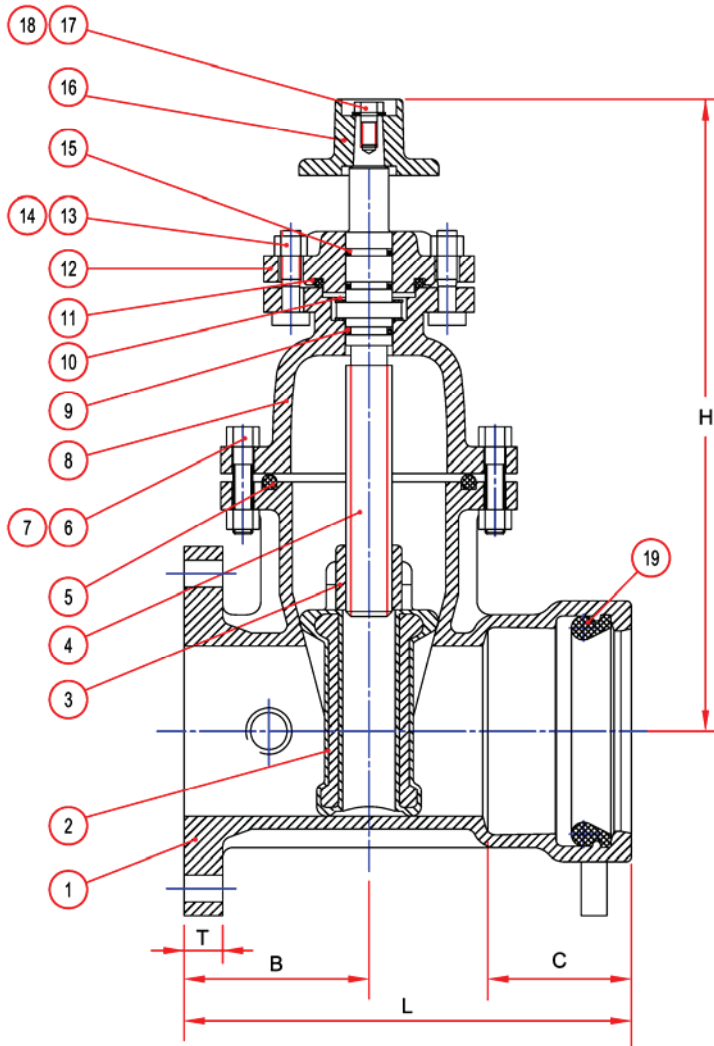

No.	Part Name	Materials
1	Body	Ductile Iron ASTM A536 65-45-12
2	Wedge	Ductile Iron EPDM Encapsulated
3	Stem Nut	Aluminum Bronze
4	Stem	Stainless Steel, Bronze Available
5	O-Ring Gasket	EPDM
6	Bolt	Stainless Steel
7	Nut	Stainless Steel
8	Bonnet	Ductile Iron ASTM A536 65-45-12
9	O-Ring	EPDM
10	Thrust Bearing	Copper
11	O-Ring	EPDM
12	Gland	Ductile Iron ASTM A536 65-45-12
13	Bolt	Stainless Steel
14	Nut	Stainless Steel
15	O-Ring	EPDM
16	2" Operating Nut	Ductile Iron ASTM A536 65-45-12
17	Bolt	Stainless Steel
18	Washer	Stainless Steel
19	Push-On Gasket	EPDM

Features:

- Design and Materials Exceed AWWA C509, C515 & C550.
- Flanges Conform to ANSI B16.1, Class 125.
Push-On End Connections for Use with Ductile Iron Pipe and C900 PVC Pipe.
- C509 Thick Wall Ductile Iron, Body, Bonnet, and Gland.
- Fusion Bonded Epoxy Coatings In and Out per AWWA C550.
- Stainless Steel Nuts, Bolts, and Washers.
- Stainless Steel Stem, Bronze Available.
- Ductile Iron, EPDM Encapsulated Wedge.
- EPDM Gaskets and O-Rings.
- 2" AWWA Ductile Iron Operating Nut.

Dimensions:

Size	Model	B	C	L	H	T	Approx. Weight
4"	6404	4½"	3½"	11"	15½"	1"	74#
6"	6406	5¼"	4"	12¾"	18¼"	1"	118#
8"	6408	5¾"	4½"	14¾"	22½"	1"	199#
10"	6410	6½"	4½"	15¾"	25½"	1"	296#
12"	6412	7"	5"	16¾"	30½"	1¼"	432#

Larger Sizes Available Upon Request